

EN

EN

EN



EUROPEAN COMMISSION

Brussels, 27.10.2010
COM(2010) 610 final

2010/0302 (COD)

Proposal for a

DIRECTIVE OF THE EUROPEAN PARLIAMENT AND OF THE COUNCIL

**on roll-over protection structures mounted in front of the driver's seat on narrow-track
wheeled agricultural and forestry tractors**

(Codification)

EXPLANATORY MEMORANDUM

1. In the context of a people's Europe, the Commission attaches great importance to simplifying and clarifying the law of the Union so as to make it clearer and more accessible to citizens, thus giving them new opportunities and the chance to make use of the specific rights it gives them.

This aim cannot be achieved so long as numerous provisions that have been amended several times, often quite substantially, remain scattered, so that they must be sought partly in the original instrument and partly in later amending ones. Considerable research work, comparing many different instruments, is thus needed to identify the current rules.

For this reason a codification of rules that have frequently been amended is also essential if the law is to be clear and transparent.

2. On 1 April 1987 the Commission decided¹ to instruct its staff that all acts should be codified after no more than ten amendments, stressing that this is a minimum requirement and that departments should endeavour to codify at even shorter intervals the texts for which they are responsible, to ensure that their provisions are clear and readily understandable.
3. The Conclusions of the Presidency of the Edinburgh European Council (December 1992) confirmed this², stressing the importance of codification as it offers certainty as to the law applicable to a given matter at a given time.

Codification must be undertaken in full compliance with the normal procedure for the adoption of acts of the Union.

Given that no changes of substance may be made to the instruments affected by codification, the European Parliament, the Council and the Commission have agreed, by an interinstitutional agreement dated 20 December 1994, that an accelerated procedure may be used for the fast-track adoption of codification instruments.

4. The purpose of this proposal is to undertake a codification of Council Directive 87/402/EEC of 25 June 1987 on roll-over protection structures mounted in front of the driver's seat on narrow-track wheeled agricultural and forestry tractors³. The new Directive will supersede the various acts incorporated in it⁴; this proposal fully preserves the content of the acts being codified and hence does no more than bring them together with only such formal amendments as are required by the codification exercise itself.

¹ COM(87) 868 PV.

² See Annex 3 to Part A of the Conclusions.

³ Carried out pursuant to the Communication from the Commission to the European Parliament and the Council – Codification of the Acquis communautaire, COM(2001) 645 final.

⁴ See Annex VIII, Part A of this proposal.

5. The codification proposal was drawn up on the basis of a preliminary consolidation, in 22 official languages, of Directive 87/402/EEC and the instruments amending it, carried out by the Publications Office of the European Union, by means of a data-processing system. Where the Articles have been given new numbers, the correlation between the old and the new numbers is shown in a table contained in Annex IX to the codified Directive.

Proposal for a

DIRECTIVE OF THE EUROPEAN PARLIAMENT AND OF THE COUNCIL

on roll-over protection structures mounted in front of the driver's seat on narrow-track wheeled agricultural and forestry tractors

(Codification)

(Text with EEA relevance)

THE EUROPEAN PARLIAMENT AND THE COUNCIL OF THE EUROPEAN UNION,

Having regard to the Treaty on the Functioning of the European Union, and in particular Article 114 thereof,

Having regard to the proposal from the European Commission,

After transmission of the draft legislative act to the national Parliaments,

Having regard to the opinion of the European Economic and Social Committee⁵,

Acting in accordance with the ordinary legislative procedure,

Whereas:



- (1) Council Directive 87/402/EEC of 25 June 1987 on roll-over protection structures mounted in front of the driver's seat on narrow-track wheeled agricultural and forestry tractors⁶ has been substantially amended several times⁷. In the interests of clarity and rationality the said Directive should be codified.

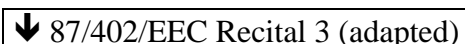

- (2) Directive 87/402/EEC is one of the separate Directives of the EC type-approval system provided for in Council Directive 74/150/EEC, as replaced by

⁵ OJ C [...], [...], p. [...].

⁶ OJ L 220, 8.8.1987, p. 1.

⁷ See Annex VIII, Part A.

Directive 2003/37/EC of the European Parliament and of the Council of 26 May 2003 on type-approval of agricultural or forestry tractors, their trailers and interchangeable towed machinery, together with their systems, components and separate technical units and repealing Directive 74/150/EEC⁸, and lays down technical prescriptions concerning the design and construction of agricultural or forestry tractors as regards the roll-over protection structures mounted in front of the driver's seat. Those technical prescriptions concern the approximation of the laws of the Member States to enable the EC type-approval procedure provided for in Directive 2003/37/EC to be applied in respect of each type of tractor. Consequently the provisions laid down in Directive 2003/37/EC relating to agricultural and forestry tractors, their trailers and interchangeable towed machinery, together with their systems, components and separate technical units, apply to this Directive. ☒



- (3) This Directive should be without prejudice to the obligations of the Member States relating to the time-limits for transposition into national law and application of the Directives set out in Annex VIII, Part B,

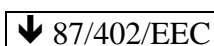

HAVE ADOPTED THIS DIRECTIVE:

Article 1



This Directive shall apply to tractors as defined in ☒ Article 2(j) of Directive 2003/37/EC ☒ having the following characteristics:

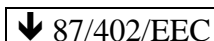

- (a) ground clearance of not more than 600 mm beneath the lowest points of the front and rear axles, allowing for the differential;
- (b) fixed or adjustable minimum track width with one of the axles less than 1 150 mm fitted with tyres of a larger size. It is assumed that the axle mounted with the wider tyres is set at a track width of not more than 1 150 mm. It must be possible to set the track width of the other axle in such a way that the outer edges of the narrower tyres do not go beyond the outer edges of the tyres of the other axle; where the two axles are fitted with rims and tyres of the same size, the fixed or adjustable track width of the two axles must be less than 1 150 mm;

⁸ OJ L 171, 9.7.2003, p. 1.

↓ 87/402/EEC (adapted)

- (c) mass greater than 600 and not more than 3 000 kilograms, corresponding to the unladen mass of the tractor as defined in point 2.1 of Model A in Annex I to Directive 2003/37/EC , including the roll-over protection structure fitted in compliance with this Directive and tyres of the largest size recommended by the manufacturer.

↓ 87/402/EEC

Article 2

1. Each Member State shall grant EC component type-approval for any type of roll-over protection structure and its tractor attachment which satisfies the construction and testing requirements laid down in Annexes I and II.

2. A Member State which has granted EC component type-approval shall take the measures required to verify, in so far as is necessary and if need be in cooperation with the competent authorities in the other Member States, that production models conform to the approved type. Such verification shall be limited to spot checks.

Article 3

↓ 87/402/EEC (adapted)

Member States shall, for each type of roll-over protection structure and its tractor attachment which they approve pursuant to Article 2, issue to the manufacturer of the tractor or of the roll-over protection structure, or to his authorised representative, an EC component type-approval mark conforming to the example shown in Annex IV.

↓ 87/402/EEC

Member States shall take all appropriate measures to prevent the use of marks liable to create confusion between roll-over protection structures which have been component type-approved pursuant to Article 2 and other devices.

↓ 87/402/EEC (adapted)

Article 4

A Member State shall not prohibit the placing on the market of roll-over protection structures or their tractor attachments on grounds relating to their construction if they bear the EC component type-approval mark.

⊗ However ⊗, a Member State may prohibit the placing on the market of roll-over protection structures bearing the EC component type-approval mark which fail to conform to the approved type.

↓ 87/402/EEC

That Member State shall forthwith inform the other Member States and the Commission of the measures taken, specifying the reasons for its decision.

Article 5

↓ 87/402/EEC (adapted)

The competent authorities of each Member State shall within one month send to the competent authorities of the other Member States copies of the EC component type-approval certificate, ⊗ the model ⊗ of which is given in Annex V, completed for each type of roll-over protection structure which they approve or refuse to approve.

↓ 87/402/EEC

Article 6

1. If the Member State which has granted EC component type-approval finds that a number of roll-over protection structures and their tractor attachments bearing the same EC component type-approval mark do not conform to the type which it has approved, it shall take the necessary measures to ensure that production models conform to the approved type.

The competent authorities of that Member State shall advise those of the other Member States of the measures taken which may, where there is a serious and repeated failure to conform, extend to the withdrawal of EC component type-approval.

Those authorities shall take the same measures if they are informed by the competent authorities of another Member State of such failure to conform.

2. The competent authorities of the Member States shall within one month inform each other of any withdrawal of EC component type-approval and of the reasons for any such measure.

Article 7

Any decision taken pursuant to the provisions adopted in implementation of this Directive to refuse or withdraw EC component type-approval for roll-over protection structures and their tractor attachments, or to prohibit their placing on the market or their use, shall set out in detail the reasons on which it is based.

Such decision shall be notified to the party concerned, who shall at the same time be informed of the remedies available to him under the laws in force in the Member States and of the time-limits allowed for the exercise of such remedies.

↓ 87/402/EEC (adapted)

Article 8

↓ 2000/22/EC (adapted)

1. With respect to tractors which comply with the requirements laid down in this Directive, Member States may not:

- (a) refuse, for a type of tractor, to grant EC type-approval or to grant national type-approval;
- (b) prohibit the first entry into service of tractors.

2. Member States

may refuse to grant national type-approval for a type of tractor if it does not comply with the requirements laid down in this Directive

↓ 87/402/EEC (adapted)

Article 9

1. No Member State may refuse the registration or prohibit the sale or use of any tractor on grounds relating to the roll-over protection structure and its tractor attachment if these bear the EC component type-approval mark and if the requirements laid down in Annex VI have been met.

However, Member States may, in compliance with the Treaty, impose restrictions on the use of tractors referred to in Article 1 in certain areas where safety so dictates, owing to the specific nature of certain terrains or crops. Member States shall inform the Commission of any such restrictions before they are implemented and of the reasons for their adoption.

↓ 87/402/EEC

2. This Directive shall not affect the right of Member States to specify, in due compliance with the Treaty, the requirements they deem necessary to ensure that workers are protected when using the tractors in question, provided this does not mean that the protection structures are modified in a way unspecified in this Directive.

Article 10

↓ 87/402/EEC (adapted)

1. In connection with EC type-approval, any tractor to which Article 1 refers shall be fitted with a roll-over protection structure.

2. The structure referred to in paragraph 1, unless it is a rear-mounted protection structure, shall comply with the requirements laid down in Annexes I and II to this Directive or in Annexes I to IV to Directives 2009/57/EC⁹ or 2009/75/EC¹⁰ of the European Parliament and of the Council.

Article 11

The amendments necessary to adapt the requirements of Annexes I to VII to take account of technical progress shall be adopted in accordance with the procedure referred to in Article 20(3) of Directive 2003/37/EC.

Article 12

Member States shall communicate to the Commission the text of the main provisions of national law which they adopt in the field covered by this Directive.

↓

Article 13

Directive 87/402/EEC, as amended by the Acts listed in Annex VIII, Part A is repealed without prejudice to the obligations of the Member States relating to the time-limits for transposition into national law and application of the Directives set out in Annex VIII, Part B.

References to the repealed Directive shall be construed as references to this Directive and shall be read in accordance with the correlation table in Annex IX.

Article 14

This Directive shall enter into force on 1 May 2011.

⁹ OJ L 261, 3.10.2009, p. 1.

¹⁰ OJ L 261, 3.10.2009, p. 40.

Article 15

This Directive is addressed to the Member States.

Done at [...]

For the European Parliament
The President

For the Council
The President

ANNEX I

CONDITIONS FOR EC COMPONENT TYPE-APPROVAL

↓ 2010/22/EU Art. 4 and Annex IV pt. 1 (adapted)

1. The definitions and requirements of point 1 of Code 6¹¹ of OECD Decision C(2008) 128 of October 2008, with the exception of point 1.1 (Agricultural and forestry tractors), shall apply, reading as follows:

"1. **Definitions**

1.1 [not applicable]

1.2 *Rolling Over Protective Structure (ROPS)*

Roll-over protective structure (safety cab or frame), hereinafter called “protective structure”, means the structure on a tractor the essential purpose of which is to avoid or limit risks to the driver resulting from roll-over of the tractor during normal use.

The roll-over protective structure is characterised by the provision of space for a clearance zone large enough to protect the driver when seated either inside the envelope of the structure or within a space bounded by a series of straight lines from the outer edges of the structure to any part of the tractor that might come into contact with flat ground and that is capable of supporting the tractor in that position if the tractor overturns.

1.3 *Track*

1.3.1 Preliminary definition: median plane of the wheel

The median plane of the wheel is equidistant from the two planes containing the periphery of the rims at their outer edges.

1.3.2 Definition of track

The vertical plane through the wheel axis intersects its median plane along a straight line which meets the supporting surface at one point. If A and B are the two points thus defined for the wheels on the same axle of the tractor, then the track width is the distance between points A and B. The track may be thus defined for both front and rear wheels. Where there are twin wheels, the track is the distance between two planes each being the median plane of the pairs of wheels.

¹¹ OECD standard code for the official testing of front mounted roll-over protective structures on narrow-track wheeled agricultural and forestry tractors.

1.3.3 Additional definition: median plane of the tractor

Take the extreme positions of points A and B for the tractor rear axle, which gives the maximum possible value for the track. The vertical plane at right angles to the line AB at its centre point is the median plane of the tractor.

1.4 *Wheelbase*

The distance between the vertical planes passing through the two lines AB as defined in point 1.3, one for the front wheels and one for the rear-wheels.

1.5 *Determination of seat index point; seat location and adjustment for test*

1.5.1 Seat index point (SIP)¹²

The seat index point shall be determined in accordance with ISO 5353:1995

1.5.2 Seat location and adjustment for test

1.5.2.1 where the inclination of the backrest and seat pan is adjustable, these must be adjusted so that the seat index point is in its rear uppermost position;

1.5.2.2 where the seat is equipped with suspension, the latter must be blocked at mid-travel, unless this is contrary to the instructions clearly laid down by the seat manufacturer;

1.5.2.3 where the position of the seat is adjustable only lengthwise and vertically, the longitudinal axis passing through the seat index point shall be parallel with the vertical longitudinal plane of the tractor passing through the centre of the steering wheel and not more than 100 mm from that plane.

1.6 *Clearance zone*

1.6.1 Reference vertical plane and line

The clearance zone (Figure 6.1 in Annex II) is defined on the basis of a vertical reference plane and a reference line:

1.6.1.1 The reference plane is a vertical plane, generally longitudinal to the tractor and passing through the seat index point and the centre of the steering wheel. Normally the reference plane coincides with the longitudinal median plane of the tractor. This reference plane shall be assumed to move horizontally with the seat and steering wheel during loading but to remain perpendicular to the tractor or the floor of the roll-over protective structure.

1.6.1.2 The reference line is the line contained in the reference plane that passes through a point located $140 + a_h$ rearward and $90 - a_v$ below the seat index point and the first point on the steering wheel rim that it intersects when brought to the horizontal.

¹² For extension tests to test reports that originally used seat reference point (SRP), the required measurements shall be made with reference to SRP instead of SIP and the use of SRP shall be clearly indicated (see Annex 1).

1.6.2 Determination of the clearance zone for tractors with a non-reversible seat

The clearance zone for tractors with a non-reversible seat is defined in points 1.6.2.1 to 1.6.2.11 and is bounded by the following planes, the tractor being on a horizontal surface, the seat, where adjustable, adjusted to its rear uppermost position¹³, and the steering wheel, where adjustable, adjusted to the mid position for seated driving:

- 1.6.2.1 two vertical planes 250 mm on either side of the reference plane, these vertical planes extending 300 mm upwards from the plane defined in point 1.6.2.8 and longitudinally at least 550 mm in front of the vertical plane perpendicular to the reference plane passing $(210 - a_h)$ mm in front of the seat index point;
- 1.6.2.2 two vertical planes 200 mm on either side of the reference plane, these vertical planes extending 300 mm upwards from the plane defined in point 1.6.2.8 and longitudinally from the surface defined in point 1.6.2.11 to the vertical plane perpendicular to the reference plane passing $(210 - a_h)$ mm in front of the seat index point;
- 1.6.2.3 an inclined plane perpendicular to the reference plane, parallel with and 400 mm above the reference line, extending backwards to the point where it intersects the vertical plane which is perpendicular to the reference plane and which passes through a point $(140 + a_h)$ mm rearward of the seat index point;
- 1.6.2.4 an inclined plane, perpendicular to the reference plane which meets the plane defined in point 1.6.2.3 at its rearmost edge and rests on the top of the seat back rest;
- 1.6.2.5 a vertical plane perpendicular to the reference plane, passing at least 40 mm forward of the steering wheel and at least $760 - a_h$ forward of the seat index point;
- 1.6.2.6 a cylindrical surface with its axis perpendicular to the reference plane, having a radius of 150 mm and tangential to the planes defined in points 1.6.2.3 and 1.6.2.5;
- 1.6.2.7 two parallel inclined planes passing through the upper edges of the planes defined in point 1.6.2.1 with the inclined plane on the side where the impact is applied no closer than 100 mm to the reference plane above the zone of clearance;
- 1.6.2.8 a horizontal plane passing through a point $90 - a_v$ below the seat index point;
- 1.6.2.9 two portions of the vertical plane perpendicular to the reference plane passing $210 - a_h$ forward of the seat index point, both these part planes joining respectively the rearmost limits of the planes defined in point 1.6.2.1 to the foremost limits of the planes defined in point 1.6.2.2 ;
- 1.6.2.10 two portions of the horizontal plane passing 300 mm above the plane defined in point 1.6.2.8 , both these part planes joining respectively the uppermost limits of the vertical planes defined in point 1.6.2.2 to the lowermost limits of the oblique planes defined in point 1.6.2.7 ;

¹³ Users are reminded that the seat index point is determined according to ISO 5353 and is a fixed point with respect to the tractor that does not move as the seat is adjusted away from the mid-position. For purposes of determining the clearance zone, the seat shall be placed in the rear and uppermost position.

1.6.2.11 a surface, curved if necessary, whose generating line is perpendicular to the reference plane and rests on the back of the seat backrest.

1.6.3 Determination of the clearance zone for tractors with a reversible driver's position

For tractors with a reversible driver's position (reversible seat and steering wheel), the clearance zone is the envelope of the two clearance zones defined by the two different positions of the steering wheel and the seat.

1.6.4 Optional seats

1.6.4.1 In case of tractors that could be fitted with optional seats, the envelope comprising the seat index points of all options offered shall be used during the tests. The protective structure shall not enter the larger clearance zone which takes account of these different seat index points.

1.6.4.2 In the case where a new seat option is offered after the test has been performed, a determination shall be made to see whether the clearance zone around the new SIP falls within the envelope previously established. If it does not, a new test must be performed.

1.7 *Permissible measurement tolerances*

Linear dimensions: ± 3 mm

except for: -- tyre deflection: ± 1 mm

-- structure deflection during horizontal loadings: ± 1 mm

-- height of fall of the pendulum block: ± 1 mm

Masses: ± 1 %

Forces: ± 2 %

Angles: ± 2 °

1.8 *Symbols*

a_h	(mm)	Half of the horizontal seat adjustment;
a_v	(mm)	Half of the vertical seat adjustment;
B	(mm)	Minimum overall width of the tractor;
B_b	(mm)	Maximum outer width of the protective structure;

D	(mm)	Deflection of the structure at the point of impact (dynamic tests) or at the point of, and in line with, the load application (static tests);
D'	(mm)	Deflection of the structure for the calculated energy required;
E _a	(J)	Strain energy absorbed at point when load is removed. Area contained within F-D curve;
E _i	(J)	Strain energy absorbed. Area under F-D curve;
E' _i	(J)	Strain energy absorbed after additional loading following a crack or tear;
E'' _i	(J)	Strain energy absorbed in overload test in the event of the load having been removed before starting this overload test. Area under F-D curve;
E _{il}	(J)	Energy input to be absorbed during longitudinal loading;
E _{is}	(J)	Energy input to be absorbed during side loading;
F	(N)	Static load force;
F'	(N)	Loading force for calculated energy required, corresponding to E' _i ;
F-D		Force/deflection diagram;
F _i	(N)	Force applied to rear hard fixture;
F _{max}	(N)	Maximum static load force occurring during loading, with the exception of the overload;
F _v	(N)	Vertical crushing force;
H	(mm)	Falling height of the pendulum block (dynamic tests);
H'	(mm)	Falling height of the pendulum block for additional test (dynamic tests);
I	(kg.m ²)	Tractor reference moment of inertia about the centre line of the rear wheels, whatever the mass of these rear wheels may be;
L	(mm)	Tractor reference wheelbase;
M	(kg)	Tractor reference mass during strength tests, as defined in point 3.2.1.4 of Annex II."

↓ 87/402/EEC (adapted)

2. GENERAL REQUIREMENTS

- 2.1. Every protection structure and its attachment to a tractor must be so designed and constructed as to fulfil the essential purpose laid down in point 1.
- 2.2. This condition is considered to be fulfilled if the requirements of Annex II are complied with.

↓ 87/402/EEC

3. APPLICATION FOR EC COMPONENT TYPE-APPROVAL

- 3.1. The application for EC component type-approval with regard to the strength of a protection structure and the strength of its attachment to a tractor must be submitted by the tractor manufacturer or by the manufacturer of the protection structure or by their authorised representatives.

↓ 87/402/EEC (adapted)

- 3.2. The application for EC component type-approval shall be accompanied by the following documents in triplicate and by the following particulars:

↓ 87/402/EEC

- a drawing, either to scale or with an indication of the principal dimensions, showing the general arrangement of the protection structure. This drawing must, in particular, show details of the mounting components,
 - photographs from side and front showing mounting details,
 - a brief description of the protection structure, including type of construction, method of mounting on the tractor and, where necessary, details of cladding and interior padding,
 - details of materials used in the structure and in the roll-over protection structure mountings (see Annex III).
- 3.3. A tractor representative of the tractor type for which the protection structure to be approved is intended must be submitted to the technical service responsible for conducting the EC component type-approval tests. This tractor must be equipped with the protection structure.

Furthermore, the manufacturer must indicate the sizes of tyres fitting or able to fit the front and rear axles.

- 3.4. The holder of EC component type-approval may request its extension to other tractor types. The competent authority which has granted the original EC component type-approval must grant the extension if the approved protection structure and the type(s) of tractor for which the extension is requested comply with the following conditions:

↓ 87/402/EEC (adapted)

- the mass of the unballasted tractor, as defined in ☒ point 2.1 of Model A of Annex I to Directive 2003/37/EC ☒ , does not exceed by more than 5% the reference mass used in the test,

↓ 87/402/EEC

- the method of attachment and the points of attachment to the tractor are identical,
- any components such as mudguards and bonnet which may provide support for the protection structure have identical strength and are identically situated with respect to the protection structure,
- the critical dimensions and the position of the seat and steering wheel relative to the protection structure, and the position relative to the protection structure of the points deemed rigid and taken into consideration for the purpose of verifying that the zone of clearance is protected, are such that the zone of clearance continues to be protected by the structure after the latter has undergone the deformation resulting from the various tests.

4. MARKINGS

- 4.1. Every protection structure conforming to the approved type must bear the following markings:
- 4.1.1. The trade mark or name;
 - 4.1.2. An EC component type-approval mark conforming to the example in Annex IV;
 - 4.1.3. Serial number of the protection structure;
 - 4.1.4. Make and type(s) of tractor(s) for which the protection structure is intended.
- 4.2. All these particulars must appear on a small plate.
- 4.3. These markings must be visible, legible and indelible.
-

ANNEX II

Technical requirements

The technical requirements for the EC type-approval of roll-over protection structures mounted in front of the driver's seat on narrow-track wheeled agricultural or forestry tractors shall be those set out in point 3 of Code 6¹⁴ of the OECD Decision C(2008) 128 of October 2008, with the exception of points 3.2.4 (Test report), 3.4.1 (Administrative extension), 3.5 (Labeling) and 3.7 (Seat belt anchorage performance), reading as follows:

"3. RULES AND DIRECTIONS

3.1 **Prior conditions for the strength tests**

3.1.1 *Completion of two preliminary tests*

The protective structure may only be subjected to the strength tests if both the Lateral Stability Test and the Non-Continuous Rolling Test have been satisfactorily completed (see flow diagram as Figure 6.3).

3.1.2 *Preparation for the preliminary tests*

3.1.2.1 The tractor must be equipped with the protective structure in its safety position.

3.1.2.2 The tractor must be fitted with tyres having the greatest diameter indicated by the manufacturer and the smallest cross-section for tyres of that diameter. The tyres must not be liquid-ballasted and must be inflated to the pressure recommended for field work.

3.1.2.3 The rear wheels must be set to the narrowest track width; the front wheels must be set as closely as possible to the same track width. If it is possible to have two front track settings which differ equally from the narrowest rear track setting, the wider of these two front track settings must be selected.

3.1.2.4 All the tractor's tanks must be filled or the liquids must be replaced by an equivalent mass in the corresponding position.

3.1.2.5 All attachments used in the series production shall be fixed to the tractor in the normal position.

¹⁴ OECD standard code for the official testing of front mounted roll-over protective structures on narrow-track wheeled agricultural and forestry tractors.

3.1.3 *Lateral stability test*

3.1.3.1 The tractor, prepared as specified above, is placed on a horizontal plane so that the tractor front-axle pivot point or, in the case of an articulated tractor, the horizontal pivot point between the two axles can move freely.

3.1.3.2 Using a jack or a hoist, tilt the part of the tractor which is rigidly connected to the axle that bears more than 50 percent of the tractor's weight, while constantly measuring the angle of inclination. This angle must be at least 38° at the moment when the tractor is resting in a state of unstable equilibrium on the wheels touching the ground. Perform the test once with the steering wheel turned to full right lock and once with the steering wheel turned to full left lock.

3.1.4 *Non-continuous rolling test*

3.1.4.1 General remarks

This test is intended to check whether a structure fitted to the tractor for the protection of the driver can satisfactorily prevent continuous roll-over of the tractor in the event of its overturning laterally on a slope with a gradient of 1 in 1,5 (Figure 6.4).

Evidence of non-continuous rolling can be provided in accordance with one of the two methods described in points 3.1.4.2 and 3.1.4.3.

3.1.4.2 Demonstration of non-continuous rolling behaviour by means of the overturning test

3.1.4.2.1 The overturning test must be carried out on a test slope at least four metres long (see Figure 6.4). The surface must be covered with an 18-cm layer of a material that, as measured in accordance with Standards ASAE S313.3 FEB1999 and ASAE EP542 FEB1999 relating to soil cone penetrometer, has a cone penetration index of:

$$A = 235 \pm 20$$

or

$$B = 335 \pm 20$$

3.1.4.2.2 The tractor (prepared as described in point 3.1.2) is tilted laterally with zero initial speed. For this purpose, it is placed at the start of the test slope in such a way that the wheels on the downhill side rest on the slope and the tractor's median plane is parallel with the contour lines. After striking the surface of the test slope, the tractor may lift itself from the surface by pivoting about the upper corner of the protective structure, but it must not roll over. It must fall back on the side which it first struck.

3.1.4.3 Demonstration of non-continuous rolling behaviour by calculation

3.1.4.3.1 For the purpose of verifying non-continuous rolling behaviour by calculation, the following characteristic tractor data must be ascertained (see Figure 6.5):

B_0 (m) Rear tyre width;

B_6	(m)	Width of protective structure between the right and left points of impact;
B_7	(m)	Width of engine bonnet;
D_0	(rad)	Front-axle swing angle from zero position to end of travel;
D_2	(m)	Height of front tyres under full axle load;
D_3	(m)	Height of rear tyres under full axle load;
H_0	(m)	Height of the front-axle pivot point;
H_1	(m)	Height of centre of gravity;
H_6	(m)	Height at the point of impact;
H_7	(m)	Height of engine bonnet;
L_2	(m)	Horizontal distance between the centre of gravity and front axle;
L_3	(m)	Horizontal distance between the centre of gravity and rear axle;
L_6	(m)	Horizontal distance between the centre of gravity and the leading point of intersection of the protective structure (to be preceded by a minus sign if this point lies in front of the plane of the centre of gravity);
L_7	(m)	Horizontal distance between the centre of gravity and the front corner of the engine bonnet;
M_c	(kg)	Tractor mass used for calculation;
Q	(kgm^2)	Moment of inertia about the longitudinal axis through the centre of gravity;
S	(m)	Rear track width.

The sum of the track (S) and tyre (B_0) widths must be greater than the width B_6 of the protective structure.

3.1.4.3.2 For the purposes of calculation, the following simplifying assumptions can be made:

3.1.4.3.2.1 the stationary tractor overturns on a slope with a 1/1,5 gradient with a balanced front axle, as soon as the centre of gravity is vertically above the axis of rotation;

3.1.4.3.2.2 the axis of rotation is parallel to the tractor's longitudinal axis and passes through the centre of the contact surfaces of the downhill front and rear wheel;

3.1.4.3.2.3 the tractor does not slide downhill;

3.1.4.3.2.4 impact on the slope is partly elastic, with a coefficient of elasticity of:

$$U = 0,2$$

3.1.4.3.2.5 the depth of penetration into the slope and the deformation of the protective structure together amount to:

$$T = 0,2 \text{ m}$$

3.1.4.3.2.6 no other components of the tractor penetrate into the slope.

3.1.4.3.3 The computer programme (BASIC¹⁵) for determining the continuous or interrupted roll-over behaviour of a laterally overturning narrow-track tractor with a front-mounted roll-over protective structure is part of the present Code, with examples 6.1 to 6.11.

3.1.5 *Measurement methods*

3.1.5.1 Horizontal distances between the centre of gravity and rear (L_3) or front (L_2) axles

The distance between the rear and front axles on both sides of the tractor shall be measured in order to verify there is no steering angle.

The distances between the centre of gravity and the rear axle (L_3) or the front axle (L_2) shall be calculated from the mass distribution of the tractor between the rear and the front wheels.

3.1.5.2 Heights of rear (D_3) and front (D_2) tyres

The distance from the highest point of the tyre to the ground plane shall be measured (Figure 6.5), and the same method shall be used for the front and rear tyres.

3.1.5.3 Horizontal distance between the centre of gravity and the leading point of intersection of the protective structure (L_6).

The distance between the centre of gravity and the leading point of intersection of the protective structure shall be measured (Figures 6.6.a, 6.6.b and 6.6.c). If the protective structure is in front of the plane of the centre of gravity, the recorded measure will be preceded by a minus sign ($-L_6$).

3.1.5.4 Width of the protective structure (B_6)

The distance between the right and left points of impact of the two vertical posts of the structure shall be measured.

The point of impact is defined by the plane tangent to the protective structure passing through the line made by the top outer points of the front and rear tyres (Figure 6.7).

¹⁵ The programme and the examples are available on the OECD website.

3.1.5.5 Height of the protective structure (H_6)

The vertical distance from the point of impact of the structure to the ground plane shall be measured.

3.1.5.6 Height of the engine bonnet (H_7)

The vertical distance from the point of impact of the engine bonnet to the ground plane shall be measured.

The point of impact is defined by the plane tangent to the engine bonnet and the protective structure passing through the top outer points of the front tyre (Figure 6.7). The measurement shall be made on both sides of the engine bonnet.

3.1.5.7 Width of the engine bonnet (B_7)

The distance between the two points of impact of the engine bonnet as defined previously shall be measured.

3.1.5.8 Horizontal distance between the centre of gravity and the front corner of the engine bonnet (L_7)

The distance from the point of impact of the engine bonnet, as defined previously, to the centre of gravity shall be measured.

3.1.5.9 Height of the front-axle pivot point (H_0)

The vertical distance between the centre of the front-axle pivot point to the centre of axle of the front tyres (H_{01}) shall be included in the manufacturer's technical report and shall be checked.

The vertical distance from the centre of the front tyres axle to the ground plane (H_{02}) shall be measured (Figure 6.8).

The height of the front-axle pivot (H_0) is the sum of both previous values.

3.1.5.10 Rear track width (S)

The minimum rear track width fitted with tyres of the largest size, as specified by the manufacturer, shall be measured (Figure 6.9).

3.1.5.11 Rear tyre width (B_0)

The distance between the outer and the inner vertical planes of a rear tyre in its upper part shall be measured (Figure 6.9).

3.1.5.12 Front axle swinging angle (D_0)

The largest angle defined by the swinging of the front axle from the horizontal position to the maximum deflection shall be measured on both sides of the axle, taking into account any end-stroke shock absorber. The maximum angle measured shall be used.

3.1.5.13 Tractor Mass (M)

The tractor mass shall be determined according to the conditions specified in point 3.2.1.4.

3.2 **Conditions for testing the strength of protective structures and of their attachment to tractors**

3.2.1 *General requirements*

3.2.1.1 Test purposes

Tests made using special rigs are intended to simulate such loads as are imposed on a protective structure, when the tractor overturns. These tests enable observations to be made on the strength of the protective structure and any brackets attaching it to the tractor and any parts of the tractor which transmit the test load.

3.2.1.2 Test methods

Tests may be performed in accordance with the dynamic procedure or the static procedure. The two methods are deemed equivalent.

3.2.1.3 General rules governing preparation for tests

3.2.1.3.1 The protective structure must conform to the series production specifications. It shall be attached in accordance with the manufacturer's recommended method to one of the tractors for which it is designed.

Note: A complete tractor is not required for the static strength test; however, the protective structure and parts of the tractor to which it is attached represent an operating installation, hereinafter referred to as 'the assembly'.

3.2.1.3.2 For both the static test and the dynamic test the tractor as assembled (or the assembly) must be fitted with all series production components which may affect the strength of the protective structure or which may be necessary for the strength test.

Components which may create a hazard in the clearance zone must also be fitted on the tractor (or the assembly) so that they may be examined to see whether the requirements of the Acceptance Conditions in point 3.2.3 have been fulfilled.

All components of the tractor or the protective structure including weather protective must be supplied or described on drawings.

3.2.1.3.3 For the strength tests, all panels and detachable non-structural components must be removed so that they may not contribute to the strengthening of the protective structure.

3.2.1.3.4 The track width must be adjusted so that the protective structure will, as far as possible, not be supported by the tyres during the strength tests. If these tests are conducted in accordance with the static procedure, the wheels may be removed.

3.2.1.4 Tractor reference mass during strength tests

The reference mass M , used in the formulae to calculate the height of the fall of the pendulum block, the loading energies and the crushing forces, must be at least the mass of the tractor, excluding optional accessories but including coolant, oils, fuel, tools plus the protective structure. Not included are optional front or rear weights, tyre ballast, mounted implements, mounted equipment or any specialised components.

3.2.2 Tests

3.2.2.1 Sequence of tests

The sequence of tests, without prejudice to the additional tests mentioned in points 3.3.1.1.6, 3.3.1.1.7, 3.3.2.1.6 and 3.3.2.1.7, is as follows:

1. impact (dynamic test) or loading (static test) at the rear of the structure
(see points 3.3.1.1.1 and 3.3.2.1.1);
2. rear crushing test (dynamic or static test)
(see points 3.3.1.1.4 and 3.3.2.1.4);
3. impact (dynamic test) or loading (static test) at the front of the structure
(see points 3.3.1.1.2 and 3.3.2.1.2);
4. impact (dynamic test) or loading (static test) at the side of the structure
(see points 3.3.1.1.3 and 3.3.2.1.3);
5. crushing at the front of the structure (dynamic or static test)
(see points 3.3.1.1.5 and 3.3.2.1.5).

3.2.2.2 General requirements

3.2.2.2.1 If, during the test, any part of the tractor restraining equipment breaks or moves, the test shall be restarted.

3.2.2.2.2 No repairs or adjustments of the tractor or protective structure may be carried out during the tests.

3.2.2.2.3 The tractor gear box shall be in neutral and the brakes off during the tests.

3.2.2.2.4 If the tractor is fitted with a suspension system between the tractor body and the wheels, it shall be blocked during the tests.



3.2.2.2.5 The side chosen for application of the first impact (dynamic test) or the first load (static test) on the rear of the structure shall be that which, in the opinion of the testing authorities, will result in the application of the series of impacts or loads under the most unfavourable conditions for the structure. The lateral impact or load

and the rear impact or load shall be applied on both sides of the longitudinal median plane of the protective structure. The front impact or load shall be applied on the same side of the longitudinal median plane of the protective structure as the lateral impact or load.

3.2.3 *Acceptance conditions*

3.2.3.1 A protective structure is regarded as having satisfied the strength requirements if it fulfils the following conditions:

3.2.3.1.1 after each part-test it must be free from cracks or tears within the meaning of points 3.3.1.2.1 or 3.2.3.1.2. If, during one of the tests, significant cracks or tears appear, an additional test, in accordance with dynamic tests or static tests, must be applied immediately after the impact or the crushing which caused cracks or tears to appear;

3.2.3.1.2 during the tests other than the overload test, no part of the protective structure must enter the clearance zone as defined in point 1.6  of  Annex I;

3.2.3.1.3 during the tests other than the overload test, all parts of the clearance zone shall be secured by the structure, in accordance with points 3.3.1.2.2 and 3.3.2.2.2;

3.2.3.1.4 during the tests the protective structure must not impose any constraints on the seat structure;

3.2.3.1.5 the elastic deflection, measured in accordance with points 3.3.1.2.3 and 3.3.2.2.3 shall be less than 250 mm.

3.2.3.2 There shall be no accessories presenting a hazard for the driver. There shall be no projecting part or accessory which is liable to injure the driver should the tractor overturn, or any accessory or part which is liable to trap him – for example by the leg or the foot – as a result of the deflections of the structure.

3.2.4 [not applicable]

3.2.5 *Apparatus and equipment for dynamic tests*

3.2.5.1 Pendulum block

3.2.5.1.1 A block acting as a pendulum must be suspended by two chains or wire ropes from pivot points not less than 6 m above the ground. Means must be provided for adjusting independently the suspended height of the block and the angle between the block and the supporting chains or wire ropes.

3.2.5.1.2 The mass of the pendulum block must be $2\,000 \pm 20$ kg excluding the mass of the chains or wire ropes which themselves must not exceed 100 kg. The length of the sides of the impact face must be 680 ± 20 mm (see Figure 6.10). The block must be filled in such a way that the position of its centre of gravity is constant and coincides with the geometrical centre of the parallelepiped.

3.2.5.1.3 The parallelepiped must be connected to the system which pulls it backwards by an instantaneous release mechanism which is so designed and located as to enable the

pendulum block to be released without causing the parallelepiped to oscillate about its horizontal axis perpendicular to the pendulum's plane of oscillation.

3.2.5.2 Pendulum supports

The pendulum pivot points must be rigidly fixed so that their displacement in any direction does not exceed 1 per cent of the height of fall.

3.2.5.3 Lashings

3.2.5.3.1 Anchoring rails with the requisite track width and covering the necessary area for lashing the tractor in all the cases illustrated (see Figures 6.11, 6.12 and 6.13) must be rigidly attached to a non-yielding base beneath the pendulum.

3.2.5.3.2 The tractor shall be lashed to the rails by means of wire rope with round strand, fibre core, construction 6 x 19 in accordance with ISO 2408:2004 and a nominal diameter of 13 mm. The metal strands must have an ultimate tensile strength of 1 770 MPa.

3.2.5.3.3 The central pivot of an articulated tractor shall be supported and lashed down as appropriate for all tests. For the lateral impact test, the pivot shall also be propped from the side opposite the impact. The front and rear wheels need not be in line if this facilitates the attachment of the wire ropes in the appropriate manner.

3.2.5.4 Wheel prop and beam

3.2.5.4.1 A softwood beam of 150 mm square shall be used as a prop for the wheels during the impact tests (see Figures 6.11, 6.12 and 6.13).

3.2.5.4.2 During the lateral impact tests, a softwood beam shall be clamped to the floor to brace the rim of the wheel opposite the side of impact (see Figure 6.13).

3.2.5.5 Props and lashings for articulated tractors

3.2.5.5.1 Additional props and lashings must be used for articulated tractors. Their purpose is to ensure that the section of the tractor on which the protective structure is fitted is as rigid as that of a non-articulated tractor.

3.2.5.5.2 Additional specific details are given in the point 3.3.1.1 for the impact and crushing tests.

3.2.5.6 Tyre pressures and deflections

3.2.5.6.1 The tractor tyres shall not be liquid-ballasted and shall be inflated to the pressures prescribed by the tractor manufacturer for field work.

3.2.5.6.2 The lashings shall be tensioned in each particular case such that the tyres undergo a deflection equal to 12 per cent of the tyre wall height (distance between the ground and the lowest point of the rim) before tensioning.

3.2.5.7 Crushing rig

A rig as shown in Figure 6.14 shall be capable of exerting a downward force on a protective structure through a rigid beam approximately 250 mm wide connected to

the load-applying mechanism by means of universal joints. Suitable axle stands shall be provided so that the tractor tyres do not bear the crushing force.

3.2.5.8 Measuring apparatus

The following measuring apparatus is needed:

3.2.5.8.1 device for measuring the elastic deflection (the difference between the maximum momentary deflection and the permanent deflection, see Figure 6.15).

3.2.5.8.2 device for checking that the protective structure has not entered the clearance zone and that the latter has remained within the structure's protective during the test (see point 3.3.2.2.2).

3.2.6 Apparatus and equipment for static tests

3.2.6.1 Static testing rig

3.2.6.1.1 The static testing rig must be designed in such a way as to permit thrusts or loads to be applied to the protective structure.

3.2.6.1.2 Provision must be made so that the load can be uniformly distributed normal to the direction of loading and along a flange having a length of one of the exact multiples of 50 between 250 and 700 mm. The stiff beam shall have a vertical face dimension of 150 mm. The edges of the beam in contact with the protective structure shall be curved with a maximum radius of 50 mm.

3.2.6.1.3 The pad shall be capable of being adjusted to any angle in relation to the load direction, in order to be able to follow the angular variations of the structure's load-bearing surface as the structure deflects.

3.2.6.1.4 Direction of the force (deviation from horizontal and vertical):

- at start of test, under zero load: $\pm 2^\circ$;
- during test, under load: 10° above and 20° below the horizontal. These variations must be kept to a minimum.

3.2.6.1.5 The deflection rate shall be sufficiently slow, less than 5 mm/s so that the load may at all moments be considered as static.

3.2.6.2 Apparatus for measuring the energy absorbed by the structure

3.2.6.2.1 The force versus deflection curve shall be plotted in order to determine the energy absorbed by the structure. There is no need to measure the force and deflection at the point where the load is applied to the structure; however, force and deflection shall be measured simultaneously and co-linearly.

3.2.6.2.2 The point of origin of deflection measurements shall be selected so as to take account only of the energy absorbed by the structure and/or by the deflection of certain parts of the tractor. The energy absorbed by the deflection and/or the slipping of the anchoring must be ignored.

3.2.6.3 Means of anchoring the tractor to the ground

3.2.6.3.1 Anchoring rails with the requisite track width and covering the necessary area for anchoring the tractor in all the cases illustrated must be rigidly attached to a non-yielding base near the testing rig.

3.2.6.3.2 The tractor must be anchored to the rails by any suitable means (plates, wedges, wire ropes, jacks, etc.) so that it cannot move during the tests. This requirement shall be checked during the test, by means of the usual devices for measuring length.

If the tractor moves, the entire test shall be repeated, unless the system for measuring the deflections taken into account for plotting the force versus deflection curve is connected to the tractor.

3.2.6.4 Crushing rig

A rig as shown in Figure 6.14 shall be capable of exerting a downward force on a protective structure through a rigid beam approximately 250 mm wide, connected to the load-applying mechanism by means of universal joints. Suitable axle stands must be provided so that the tractor tyres do not bear the crushing force.

3.2.6.5 Other measuring apparatus

The following measuring devices are also needed:

3.2.6.5.1 device for measuring the elastic deflection (the difference between the maximum momentary deflection and the permanent deflection, see Figure 6.15).

3.2.6.5.2 device for checking that the protective structure has not entered the clearance zone and that the latter has remained within the structure's protection during the test (point 3.3.2.2.2).

3.3 Test procedures

3.3.1 *Dynamic Tests*

3.3.1.1 Impact and crushing tests

3.3.1.1.1 Impact at the rear

3.3.1.1.1.1 The tractor shall be so placed in relation to the pendulum block that the block will strike the protective structure when the impact face of the block and the supporting chains or wire ropes are at an angle with the vertical plane A equal to $M/100$ with a 20° maximum, unless, during deflection, the protective structure at the point of contact forms a greater angle to the vertical. In this case the impact face of the block shall be adjusted by means of an additional support so that it is parallel to the protective structure at the point of impact at the moment of maximum deflection, the supporting chains or wire ropes remaining at the angle defined above.

The suspended height of the block shall be adjusted and necessary steps taken so as to prevent the block from turning about the point of impact.

The point of impact is that part of the protective structure likely to hit the ground first in a rearward overturning accident, normally the upper edge. The position of the centre of gravity of the block is 1/6 of the width of the top of the protective structure inwards from a vertical plan parallel to the median plane of the tractor touching the outside extremity of the top of the protective structure.

If the structure is curved or protruding at this point, wedges enabling the impact to be applied thereon must be added, without thereby reinforcing the structure.

3.3.1.1.1.2 The tractor must be lashed to the ground by means of four wire ropes, one at each end of both axles, arranged as indicated in Figure 6.11. The spacing between the front and rear lashing points must be such that the wire ropes make an angle of less than 30° with the ground. The rear lashings must in addition be so arranged that the point of convergence of the two wire ropes is located in the vertical plane in which the centre of gravity of the pendulum block travels.

The wire ropes must be tensioned so that the tyres undergo the deflections given in point 3.2.5.6.2. With the wire ropes tensioned, the wedging beam shall be placed in front of and tight against the rear wheels and then fixed to the ground.

3.3.1.1.1.3 If the tractor is of the articulated type, the point of articulation shall, in addition, be supported by a wooden block at least 100 mm square and firmly lashed to the ground.

3.3.1.1.1.4 The pendulum block shall be pulled back so that the height of its centre of gravity above that at the point of impact is given by one of the following two formulae, to be chosen according to the reference mass of the assembly subjected to the tests:

$$H = 25 + 0.07 M$$

for tractor with a reference mass of less than 2 000 kg;

$$H = 125 + 0.02 M$$

for tractor with a reference mass of more than 2 000 kg.

The pendulum block is then released and strikes the protective structure.

3.3.1.1.1.5 For tractors with a reversible driver's position (reversible seat and steering wheel), the same formulae shall apply.

3.3.1.1.2 Impact at the front

3.3.1.1.2.1 The tractor shall be so placed in relation to the pendulum block that the block will strike the protective structure when the impact face of the block and the supporting chains or wire ropes are at an angle with the vertical plane A equal to $M/100$ with a 20° maximum, unless, during deflection, the protective structure at the point of contact forms a greater angle to the vertical. In this case the impact face of the block shall be adjusted by means of an additional support so that it is parallel to the protective structure at the point of impact at the moment of maximum deflection, the supporting chains or wire ropes remaining at the angle defined above.

The suspended height of the pendulum block shall be adjusted and the necessary steps taken so as to prevent the block from turning about the point of impact.

The point of impact is that part of the protective structure likely to hit the ground first if the tractor overturned sideways while travelling forward, normally the upper edge. The position of the centre of gravity of the block is 1/6 of the width of the top of the protective structure inwards from a vertical plane parallel to the median plane of the tractor touching the outside extremity of the top of the protective structure.

If the structure is curved or protruding at this point, wedges enabling the impact to be applied thereon must be added, without thereby reinforcing the structure.

3.3.1.1.2.2 The tractor must be lashed to the ground by means of four wire ropes, one at each end of both axles, arranged as indicated in Figure 6.12. The spacing between the front and rear lashing points must be such that the wire ropes make an angle of less than 30° with the ground. The rear lashings shall in addition be so arranged that the point of convergence of the two wire ropes is located in the vertical plane in which the centre of gravity of the pendulum block travels.

The wire ropes must be tensioned so that the tyres undergo the deflections given in point 3.2.5.6.2. With the wire ropes tensioned, the wedging beam shall be placed behind and tight against the rear wheels and then fixed to the ground.

3.3.1.1.2.3 If the tractor is of the articulated type, the point of articulation shall, in addition, be supported by a wooden block at least 100 mm square and firmly lashed to the ground.

3.3.1.1.2.4 The pendulum block shall be pulled back so that the height of its centre of gravity above that at the point of impact is given by one of the following two formulae, to be chosen according to the reference mass of the assembly subjected to the tests:

$$H = 25 + 0.07 M$$

for tractor with a reference mass of less than 2 000 kg;

$$H = 125 + 0.02 M$$

for tractor with a reference mass of more than 2 000 kg.

The pendulum block is then released and strikes the protective structure.

3.3.1.1.2.5 For tractors with a reversible driver's position (reversible seat and steering wheel), the height shall be whichever is greater from the formula applied above and that selected below:

$$H = 2.165 \times 10^{-8} M \times L^2$$

or

$$H = 5.73 \times 10^{-2} I$$

3.3.1.1.3 Impact from the side

3.3.1.1.3.1 The tractor shall be so placed in relation to the pendulum block that the block will strike the protective structure when the impact face of the block and the supporting chains or wire ropes are vertical unless, during deflection, the protective structure at the point of contact forms an angle of less than 20° to the vertical. In this case the impact face of the block shall be adjusted by means of an additional support so that it is parallel to the protective structure at the point of impact at the moment of maximum deflection, the supporting chains or wire ropes remaining vertical on impact.

The suspended height of the pendulum block shall be adjusted and necessary steps taken so as to prevent the block from turning about the point of impact.

The point of impact shall be that part of the protective structure likely to hit the ground first in a sideways overturning accident.

3.3.1.1.3.2 The tractor wheels on the side which is to receive the impact must be lashed to the ground by means of wire ropes passing over the corresponding ends of the front and rear axles. The wire ropes must be tensioned to produce the tyre deflection values given in point 3.2.5.6.2.

With the wire ropes tensioned, the wedging beam shall be placed on the ground, pushed tight against the tyres on the side opposite that which is to receive the impact and then fixed to the ground. It may be necessary to use two beams or wedges if the outer sides of the front and rear tyres are not in the same vertical plane. The prop shall then be placed as indicated in Figure 6.13 against the rim of the most heavily loaded wheel opposite to the point of impact, pushed firmly against the rim and then fixed at its base. The length of the prop shall be such that it makes an angle of $30 \pm 3^\circ$ with the ground when in position against the rim. In addition, its thickness shall, if possible, be between 20 and 25 times less than its length and between 2 and 3 times less than its width. The props shall be shaped at both ends as shown in the details on Figure 6.13.

3.3.1.1.3.3 If the tractor is of the articulated type, the point of articulation shall in addition be supported by a wooden block at least 100 mm square and laterally supported by a device similar to the prop pushed against the rear wheel as in point 3.3.1.1.3.2. The point of articulation shall then be lashed firmly to the ground.

3.3.1.1.3.4 The pendulum block shall be pulled back so that the height of its centre of gravity above that at the point of impact is given by one of the following two formulae, to be chosen according to the reference mass of the assembly subjected to the tests:

$$H = (25 + 0.20 M) (B_6 + B) / 2B$$

for tractor with a reference mass of less than 2 000 kg;

$$H = (125 + 0.15 M) (B_6 + B) / 2B$$

for tractor with a reference mass of more than 2 000 kg.

3.3.1.1.3.5 For reversible tractors, the height shall be whichever is greater of the results obtained from the formulae applicable above and below:

$$H = 25 + 0.2 M$$

for tractor with a reference mass of less than 2 000 kg;

$$H = 125 + 0.15 M$$

for tractor with a reference mass of more than 2 000 kg.

The pendulum block is then released and strikes the protective structure.

3.3.1.1.4Crushing at the rear

The beam shall be positioned over the rear uppermost structural member(s) and the resultant of crushing forces shall be located in the tractor's median plane. A force F_v shall be applied where:

$$F_v = 20 M$$

The force F_v shall be maintained for five seconds after cessation of any visually detectable movement of the protective structure.

Where the rear part of the protective structure roof will not sustain the full crushing force, the force shall be applied until the roof is deflected to coincide with the plane joining the upper part of the protective structure with that part of the rear of the tractor capable of supporting the tractor when overturned.

The force shall then be removed, and the crushing beam repositioned over that part of the protective structure which would support the tractor when completely overturned. The crushing force F_v shall then be applied again.

3.3.1.1.5Crushing at the front

The beam shall be positioned across the front uppermost structural member(s) and the resultant of crushing forces shall be located in the tractor's median plane. A force F_v shall be applied where:

$$F_v = 20 M$$

The force F_v shall be maintained for five seconds after the cessation of any visually detectable movement of the protective structure.

Where the front part of the protective structure roof will not sustain the full crushing force, the force shall be applied until the roof is deflected to coincide with the plane joining the upper part of the protective structure with that part of the front of the tractor capable of supporting the tractor when overturned.

The force shall then be removed, and the crushing beam repositioned over that part of the protective structure which would support the tractor when completely overturned. The crushing force F_v shall then be applied again.

3.3.1.1.6 Additional impact tests

If cracks or tears which cannot be considered negligible appear during an impact test, a second, similar test, but with a height of fall of:

$$H' = (H \times 10^{-1}) (12 + 4a) (1 + 2a)^{-1}$$

shall be performed immediately after the impact tests causing these tears or cracks to appear, 'a' being the ratio of the permanent deformation (D_p) to the elastic deformation (D_e):

$$a = D_p / D_e$$

as measured at the point of impact. The additional permanent deformation due to the second impact shall not exceed 30 per cent of the permanent deformation due to the first impact.

In order to be able to carry out the additional test, it is necessary to measure the elastic deformation during all the impact tests.

3.3.1.1.7 Additional crushing tests

If during a crushing test, significant cracks or tears appear, a second, similar, crushing test, but with a force equal to $1.2 F_v$ shall be performed immediately after the crushing tests which caused these tears or cracks to appear.

3.3.1.2 Measurements to be made

3.3.1.2.1 Fractures and cracks

After each test all structural members, joints and fastening systems shall be visually examined for fractures or cracks, any small cracks in unimportant parts being ignored.

Any tears caused by the edges of the pendulum weight are to be ignored.

3.3.1.2.2 Clearance zone

3.3.1.2.2.1 Entry into the clearance zone

During each test the protective structure shall be examined to see whether any part of it has entered the clearance zone round the driving seat as defined in point 1.6.

Furthermore, the clearance zone shall not be outside the protection of the protective structure. For this purpose, it shall be considered to be outside the protection of the structure if any part of it would come in contact with flat ground if the tractor overturned towards the direction from which the test load is applied. For estimating this, the front and rear tyres and track width setting shall be the smallest standard fitting specified by the manufacturer.

3.3.1.2.2.2 Rear hard fixture tests

If the tractor is fitted with a rigid section, a housing or other hard fixture placed behind the driver's seat, this fixture shall be regarded as a protective point, in the event of sideways or rear overturning. This hard fixture placed behind the driver's seat shall be capable of withstanding, without breaking or entering the clearance zone, a downward force F_i where:

$$F_i = 15 M$$

applied perpendicularly to the top of the frame in the central plane of the tractor. The initial angle of application of force shall be 40° calculated from a parallel to the ground as shown in Figure 6.16. The minimum width of this rigid section shall be 500 mm (see Figure 6.17).

In addition, it shall be sufficiently rigid and firmly attached to the rear of the tractor.

3.3.1.2.3 Elastic deflection (under side impact)

The elastic deflection is measured $(810 + a_v)$ mm above the index point, in the vertical plane passing through the point of impact. For this measurement, apparatus similar to that illustrated in Figure 6.15 shall be used.

3.3.1.2.4 Permanent deflection

After the final crushing test, the permanent deflection of the protective structure shall be recorded. For this purpose, before the start of the test, the position of the main roll-over protective structure members in relation to the seat index point shall be used.

3.3.2 Static Tests

3.3.2.1 Loading and crushing tests

3.3.2.1.1 Loading at the rear

3.3.2.1.1.1 The load shall be applied horizontally in a vertical plane parallel to the tractor's median plane.

The load application point shall be that part of the roll-over protective structure likely to hit the ground first in a rearward overturning accident, normally the upper edge. The vertical plane in which the load is applied shall be located at a distance of $1/3$ of the external width of the upper part of the structure from the median plane.

If the structure is curved or protruding at this point, wedges enabling the load to be applied thereon shall be added, without thereby reinforcing the structure.

3.3.2.1.1.2 The assembly shall be lashed to the ground as described in point 3.2.6.3.

3.3.2.1.1.3 The energy absorbed by the protective structure during the test shall be at least:

$$E_{il} = 500 + 0.5 M$$

3.3.2.1.1.4 For tractors with a reversible driver's position (reversible seat and steering wheel), the same formula shall apply.

3.3.2.1.2 Loading at the front

3.3.2.1.2.1 The load shall be applied horizontally, in a vertical plane parallel to the tractor's median plane and located at a distance of 1/3 of the external width of the upper part of the structure.

The load application point shall be that part of the roll-over protective structure likely to hit the ground first if the tractor overturned sideways while travelling forward, normally the upper edge.

If the structure is curved or protruding at this point, wedges enabling the load to be applied thereon shall be added, without thereby reinforcing the structure.

3.3.2.1.2.2 The assembly shall be lashed to the ground as described in point 3.2.6.3.

3.3.2.1.2.3 The energy absorbed by the protective structure during the test shall be at least:

$$E_{il} = 500 + 0.5 M$$

3.3.2.1.2.4 For tractors with a reversible driver's position (reversible seat and steering wheel), the energy shall be whichever is the higher of the above or either of the following as selected:

$$E_{il} = 2.165 \times 10^{-7} M \times L^2$$

or

$$E_{il} = 0.574 I$$

3.3.2.1.3 Loading from the side

3.3.2.1.3.1 The side loading shall be applied horizontally, in a vertical plane perpendicular to the tractor's median plane. The load application point shall be that part of the roll-over protective structure likely to hit the ground first in a sideways overturning accident, normally the upper edge.

3.3.2.1.3.2 The assembly shall be lashed to the ground as described in point 3.2.6.3.

3.3.2.1.3.3 The energy absorbed by the protective structure during the test shall be at least:

$$E_{is} = 1.75 M(B_G + B) / 2B$$

3.3.2.1.3.4 For tractors with a reversible driver's position (reversible seat and steering wheel), the energy shall be whichever is higher of the above or the following:

$$E_{is} = 1.75 M$$

3.3.2.1.4 Crushing at the rear

All provisions are identical to those given in point 3.3.1.1.4.

3.3.2.1.5 Crushing at the front

All provisions are identical to those given in point 3.3.1.1.5.

3.3.2.1.6 Additional overload test (Figures 6.18 to 6.20)

An overload test shall be carried out in all cases where the force decreases by more than 3 per cent during the last 5 per cent of the deflection reached when the energy required is absorbed by the structure (see Figure 6.19).

The overload test involves the gradual increase of the horizontal load by increments of 5 per cent of the initial energy requirement up to a maximum of 20 per cent of energy added (see Figure 6.20).

The overload test is satisfactory if, after each increase by 5, 10, or 15 per cent in the energy required, the force decreases by less than 3 per cent for a 5 per cent increment and remains greater than $0.8 F_{\max}$.

The overload test is satisfactory if, after the structure has absorbed 20 per cent of the added energy, the force exceeds $0.8 F_{\max}$.

Additional cracks or tears and/or entry into or lack of protective of the clearance zone due to elastic deflection are permitted during the overload test. However, after the removal of the load, the structure shall not enter the clearance zone, which shall be completely protected.

3.3.2.1.7 Additional crushing tests

If cracks or tears which cannot be considered as negligible appear during a crushing test, a second, similar crushing, but with a force of $1.2 F_v$ shall be applied immediately after the crushing test which caused the cracks or tears to appear.

3.3.2.2 Measurements to be made

3.3.2.2.1 Fractures and cracks

After each test all structural members, joints and attachment systems shall be visually examined for fractures or cracks, any small cracks in unimportant parts being ignored.

3.3.2.2.2 Clearance zone

3.3.2.2.2.1 Entry into the clearance zone

During each test the protective structure shall be examined to see whether any part of it has entered the clearance zone as defined in 1.6 in Annex I.

Furthermore, the clearance zone shall not be outside the protection of the protective structure. For this purpose, it shall be considered to be outside the protection of the structure if any part of it would come in contact with flat ground if the tractor overturned towards the direction from which the test load is applied. For estimating this, the front and rear tyres and track width setting shall be the smallest standard fitting specified by the manufacturer.

3.3.2.2.2.2 Rear hard fixture tests

If the tractor is fitted with a rigid section, a housing or other hard fixture placed behind the driver's seat, this fixture shall be regarded as a protective point, in the event of sideways or rear overturning. This hard fixture placed behind the driver's seat shall be capable of withstanding, without breaking or entering the clearance zone, a downward force F_i , where:

$$F_i = 15 M$$

applied perpendicularly to the top of the frame in the central plane of the tractor. The initial angle of application of force shall be 40° calculated from a parallel to the ground as shown in Figure 6.16. The minimum width of this rigid section shall be 500 mm (see Figure 6.17).

In addition, it shall be sufficiently rigid and firmly attached to the rear of the tractor.

3.3.2.2.3 Elastic deflection under side loading

The elastic deflection shall be measured $(810+a_v)$ mm above the seat index point, in the vertical plane in which the load is applied. For this measurement, any apparatus similar to that illustrated in Figure 6.15 shall be used.

3.3.2.2.4 Permanent deflection

After the final crushing test the permanent deflection of the protective structure shall be recorded. For this purpose, before the start of the test, the position of the main roll-over protective structure members in relation to the seat index point shall be recorded.

3.4 Extension to other tractor models

3.4.1 [not applicable]

3.4.2 *Technical extension*

When technical modifications occur on the tractor, the protective structure or the method of attachment of the protective structure to the tractor, the testing station that has carried out the original test can issue a "technical extension report" if the tractor and protective structure satisfied preliminary tests of lateral stability and non-continuous rolling as defined in points 3.1.3 and 3.1.4 and if the rear hard fixture as described in point 3.3.1.2.2.2, when fitted, has been tested in accordance with the procedure described in this point (except point 3.4.2.2.4) in the following cases:

3.4.2.1 Extension of the structural test results to other models of tractors

The impact or loading and crushing tests need not be carried out on each model of tractor, provided that the protective structure and tractor comply with the conditions referred to \boxtimes in points \boxtimes 3.4.2.1.1 to 3.4.2.1.5.

3.4.2.1.1 The structure (including rear hard fixture) shall be identical to the one tested;

3.4.2.1.2 The required energy shall not exceed the energy calculated for the original test by more than 5 per cent;

3.4.2.1.3 The method of attachment and the tractor components to which the attachment is made shall be identical;

3.4.2.1.4 Any components such as mudguards and bonnet that may provide support for the protective structure shall be identical;

3.4.2.1.5 The position and critical dimensions of the seat in the protective structure and the relative position of the protective structure on the tractor shall be such that the clearance zone would have remained within the protection of the deflected structure throughout all tests (this shall be checked by using the same reference of clearance zone as in the original test report, respectively Seat Reference Point [SRP] or Seat Index Point [SIP]).

3.4.2.2 Extension of the structural test results to modified models of the protective structure

This procedure has to be followed when the provisions of point 3.4.2.1 are not fulfilled. It may not be used when the method of attachment of the protective structure to the tractor does not remain of the same principle (e.g. rubber supports replaced by a suspension device):

3.4.2.2.1 Modifications having no impact on the results of the initial test (e.g. weld attachment of the mounting plate of an accessory in a non-critical location on the structure), addition of seats with different SIP location in the protective structure (subject to checking that the new clearance zone(s) remain(s) within the protection of the deflected structure throughout all tests).

3.4.2.2.2 Modifications having a possible impact on the results of the original test without calling into question the acceptability of the protective structure (e.g. modification of a structural component, modification of the method of attachment of the protective structure to the tractor). A validation test can be carried out and the test results will be drafted in the extension report.

The following limits for this type extension are fixed:

3.4.2.2.2.1 no more than 5 extensions may be accepted without a validation test;

3.4.2.2.2.2 the results of the validation test will be accepted for extension if all the acceptance conditions of the Code are fulfilled and:

- if the deflection measured after each impact test does not deviate from the deflection measured after each impact test in the original test report by more than $\pm 7\%$ (in the case of dynamic tests);
- if the force measured when the required energy level has been reached in the various horizontal load tests does not deviate from the force measured when the required energy has been reached in the original test by more than $\pm 7\%$

and the deflection measured¹⁶ when the required energy level has been reached in the various horizontal load tests does not deviate from the deflection measured when the required energy has been reached in the original test report by more than $\pm 7\%$ (in the case of static tests).

3.4.2.2.2.3 more than one protective structure modifications may be included in a single extension report if they represent different options of the same protective structure, but only one validation test can be accepted in a single extension report. The options not tested shall be described in a specific section of the extension report.

3.4.2.2.3 Increase of the reference mass declared by the manufacturer for a protective structure already tested. If the manufacturer wants to keep the same approval number it is possible to issue an extension report after having carried out a validation test (the limits of $\pm 7\%$ specified in point 3.4.2.2.2 are not applicable in such a case).

3.4.2.2.4 Modification of the rear hard fixture or addition of a new rear hard fixture. It has to be checked that the clearance zone remains within the protection of the deflected structure throughout all test taking into account the new or modified rear hard fixture. A validation of the rear hard fixture consisting in the test described in points 3.3.1.2.2.2 or 3.3.2.2.2.2 has to be carried out and the test results will be drafted in the extension report.

3.5 [not applicable]

3.6 Cold weather performance of protective structures

3.6.1 If the protective structure is claimed to have properties resistant to cold weather embrittlement, the manufacturer shall give details that shall be included in the report.

3.6.2 The following requirements and procedures are intended to provide strength and resistance to brittle fracture at reduced temperatures. It is suggested that the following minimum material requirements shall be met in judging the protective structure's suitability at reduced operating temperatures in those countries requiring this additional operating protection.

3.6.2.1 Bolts and nuts used to attach the protective structure to the tractor and used to connect structural parts of the protective structure shall exhibit suitable controlled reduced temperature toughness properties.

3.6.2.2 All welding electrodes used in the fabrication of structural members and mounts shall be compatible with the protective structure material as given in point 3.6.2.3 .

3.6.2.3 Steel materials for structural members of the protective structure shall be of controlled toughness material exhibiting minimum Charpy V-Notch impact energy requirements as shown in Table 6.1. Steel grade and quality shall be specified in accordance with ISO 630:1995.

Steel with an as-rolled thickness less than 2.5 mm and with a carbon content less than 0.2 per cent is considered to meet this requirement.

¹⁶ Permanent + elastic deflection measured at the point when the required energy level is obtained.

Structural members of the protective structure made from materials other than steel shall have equivalent low temperature impact resistance.

- 3.6.2.4 When testing the Charpy V-Notch impact energy requirements, the specimen size shall be no less than the largest of the sizes stated in Table 6.1 that the material will permit.
- 3.6.2.5 The Charpy V-Notch tests shall be made in accordance with the procedure in ASTM A 370-1979, except for specimen sizes that shall be in accordance with the dimensions given in Table 6.1.
- 3.6.2.6 Alternatives to this procedure are the use of killed or semi-killed steel for which an adequate specification shall be provided. Steel grade and quality shall be specified in accordance with ISO 630:1995, Amd 1:2003.
- 3.6.2.7 Specimens are to be longitudinal and taken from flat stock, tubular or structural sections before forming or welding for use in the protective structure. Specimens from tubular or structural sections are to be taken from the middle of the side of greatest dimension and shall not include welds.

Table 6.1

Minimum Charpy V-notch impact energies

Specimen size	Energy at	Energy at
	-30 °C	-20 °C
mm	J	J ^{b)}
10 x 10 ^{a)}	11	27,5
10 x 9	10	25
10 x 8	9,5	24
10 x 7,5 ^{a)}	9,5	24
10 x 7	9	22,5
10 x 6,7	8,5	21
10 x 6	8	20
10 x 5 ^{a)}	7,5	19
10 x 4	7	17,5

10 x 3.5	6	15
10 x 3	6	15
10 x 2.5 ^{a)}	5,5	14

- (a) Indicates preferred size. Specimen size shall be no less than largest preferred size that the material permits.
- (b) The energy requirement at $-20\text{ }^{\circ}\text{C}$ is 2,5 times the value specified for $-30\text{ }^{\circ}\text{C}$. Other factors affect impact energy strength, i.e. direction of rolling, yield strength, grain orientation and welding. These factors shall be considered when selecting and using steel.

3.7 [not applicable]

Figure 6.1

Clearance zone

Figure 6.1.a

Side view

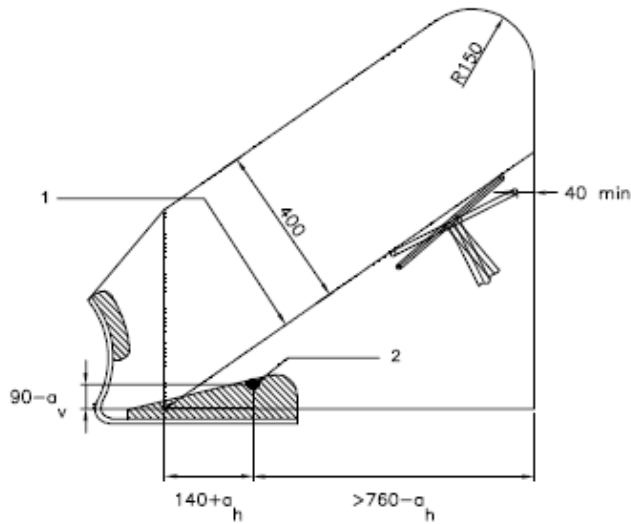
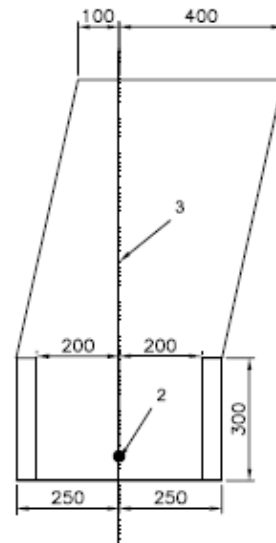

Figure 6.1.b

Rear view



Cross-section through the reference plane

Dimensions in mm

Figure 6.1.c

View from above

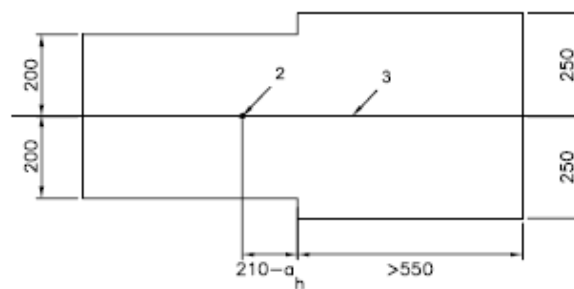

- 1 – Reference line
- 2 – Seat index point
- 3 – Reference plane

Figure 6.2

Clearance zone for tractors with reversible seat and steering wheel

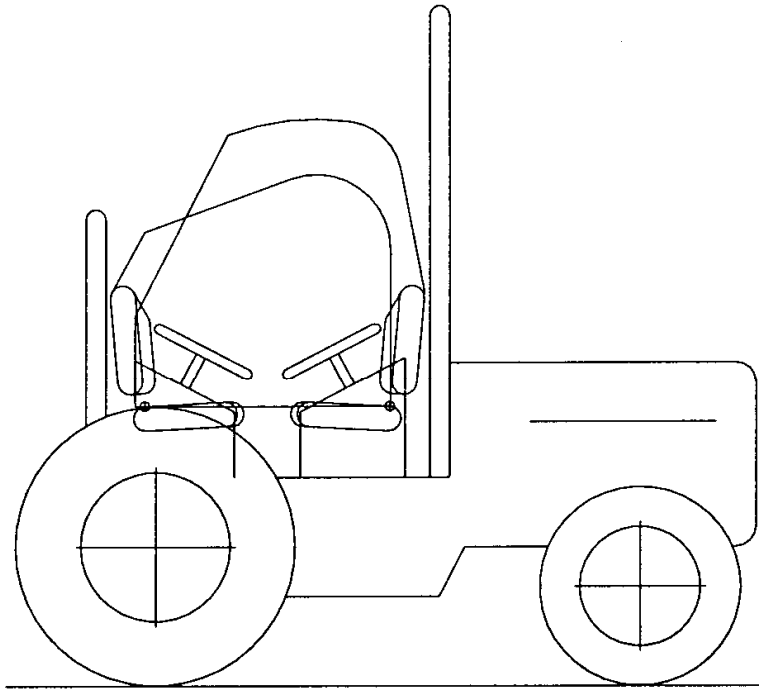
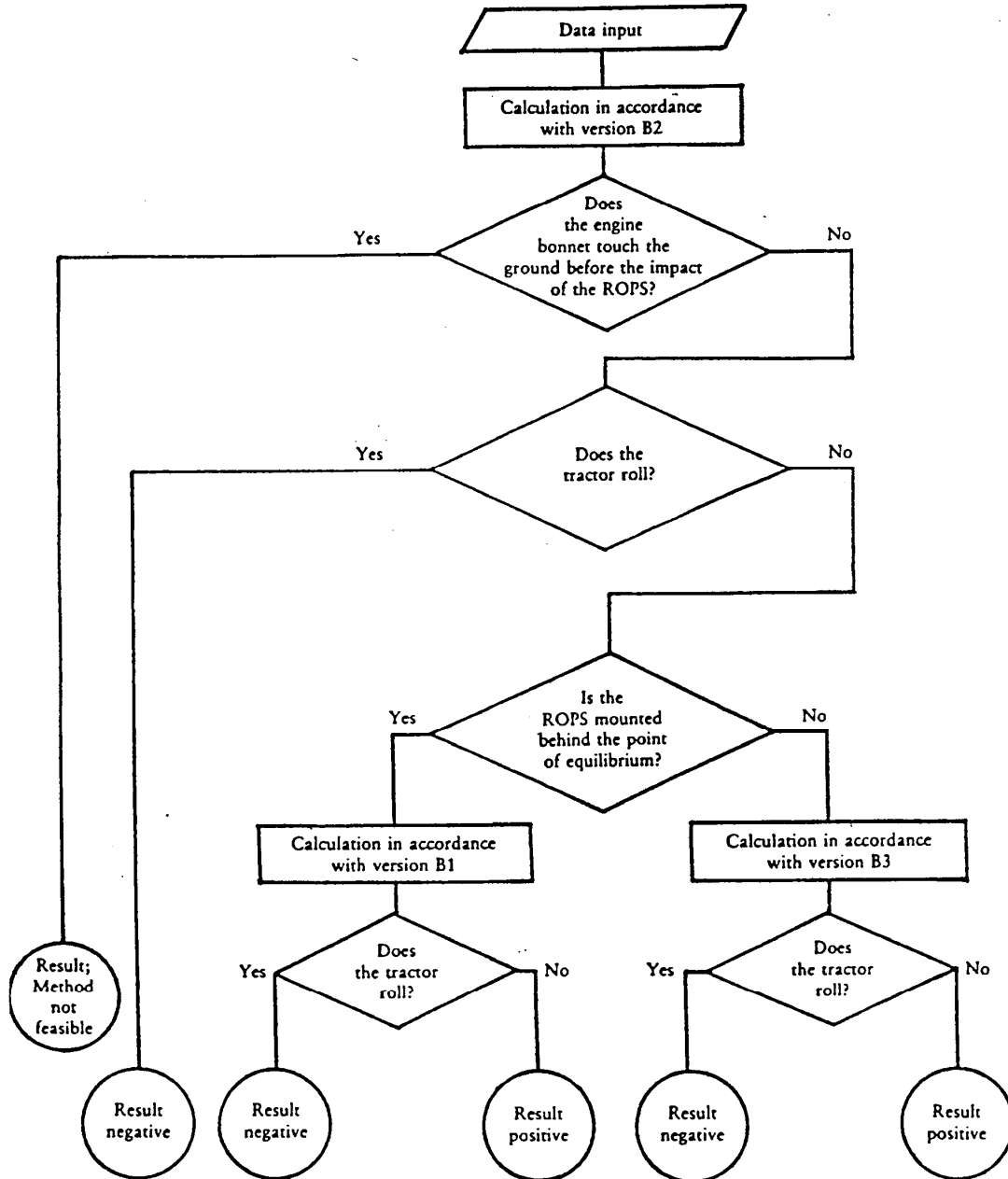

Figure 6.3

Flow diagram for determining the continuous roll-over behaviour of a laterally overturning tractor with a front mounted roll-over protective structure (ROPS)



Version B1: Point of impact of ROPS behind longitudinally unstable equilibrium point

Version B2: Point of impact of ROPS near longitudinally unstable equilibrium point

Version B3: Point of impact of ROPS in front of longitudinally unstable equilibrium point

Figure 6.4

Rig for testing anti-roll properties on 1/ 1,5 gradient

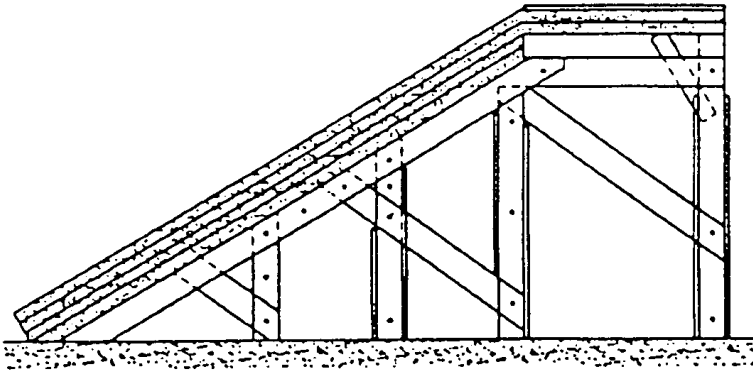
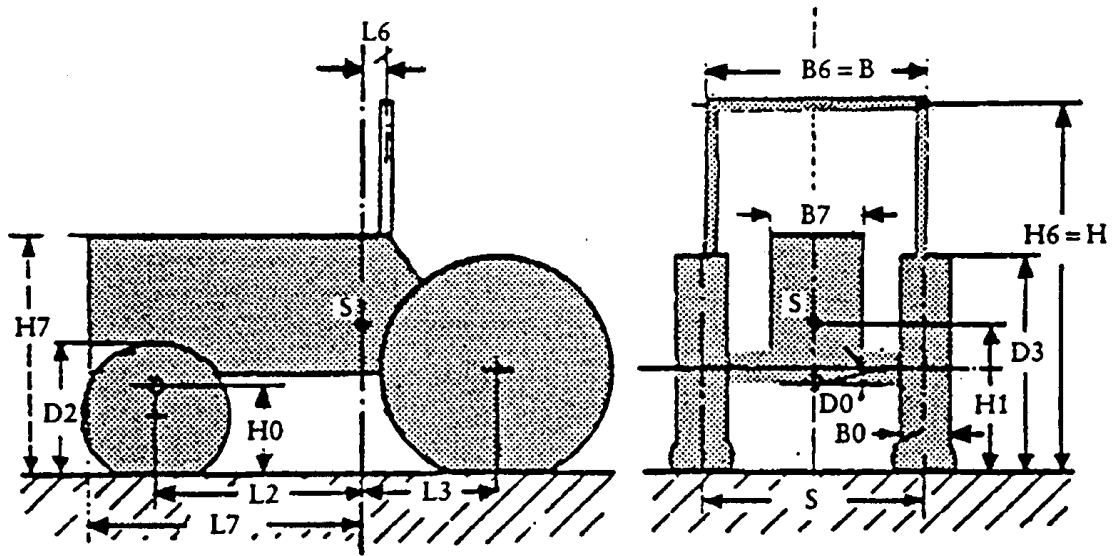

Figure 6.5

Data required for calculating the overturn of a tractor with triaxial rolling behaviour



Note: D_2 and D_3 should be measured under full axle load.

Figures 6.6.a, 6.6.b, 6.6.c

**Horizontal distance between the centre of gravity
and the leading point of intersection of the protective structure (L6)**

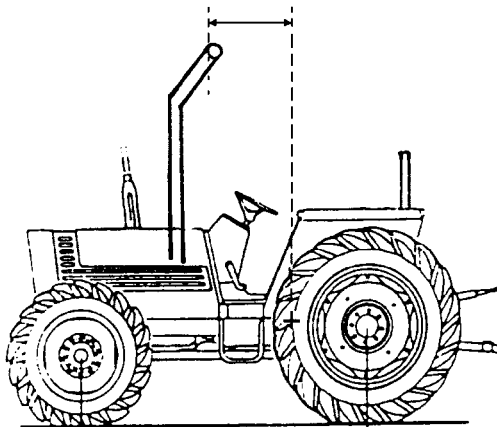
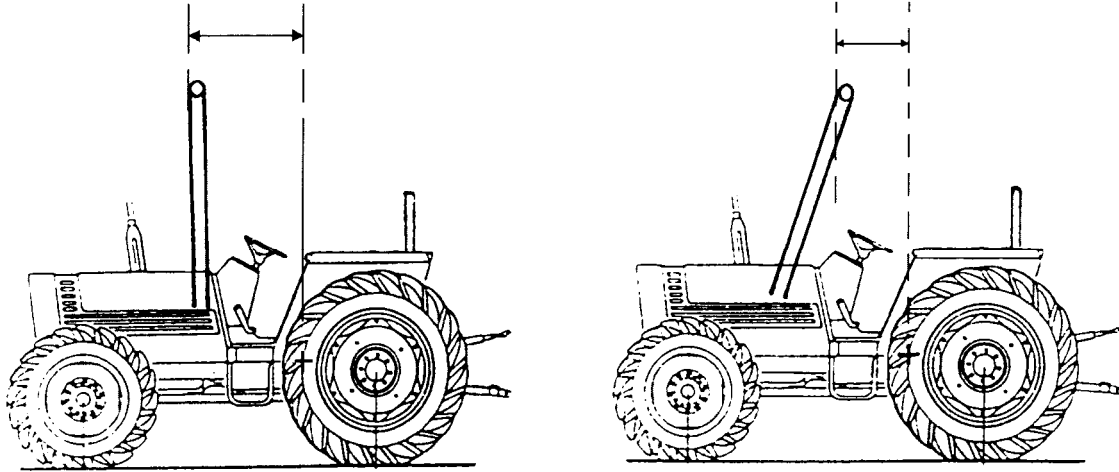

Figure 6.7

**Determination of points of impact
for measurement of width of protective structure (B_6)
and height of engine bonnet (H_7)**

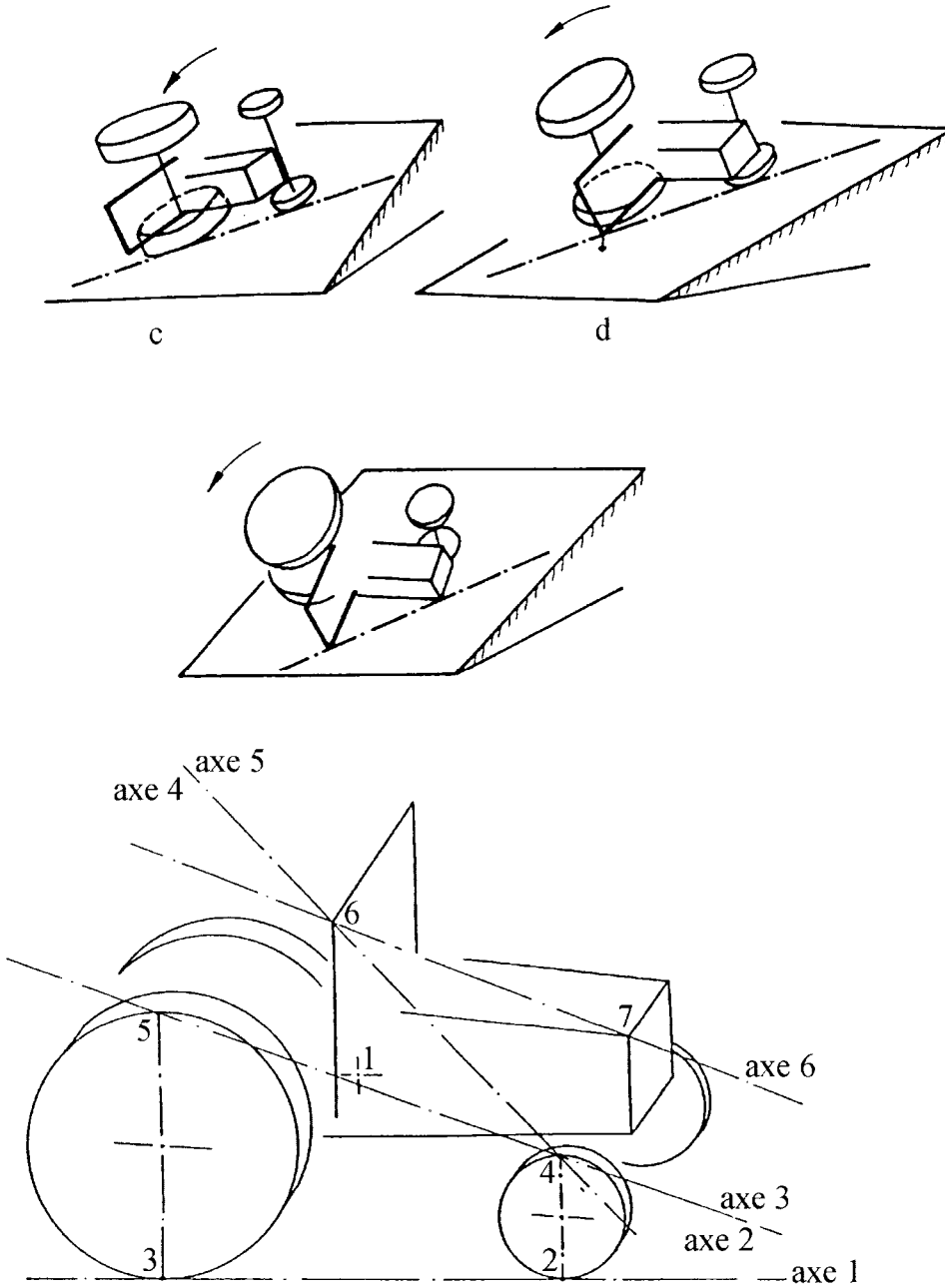

Figure 6.8

Height of the front-axle pivot point (H_0)

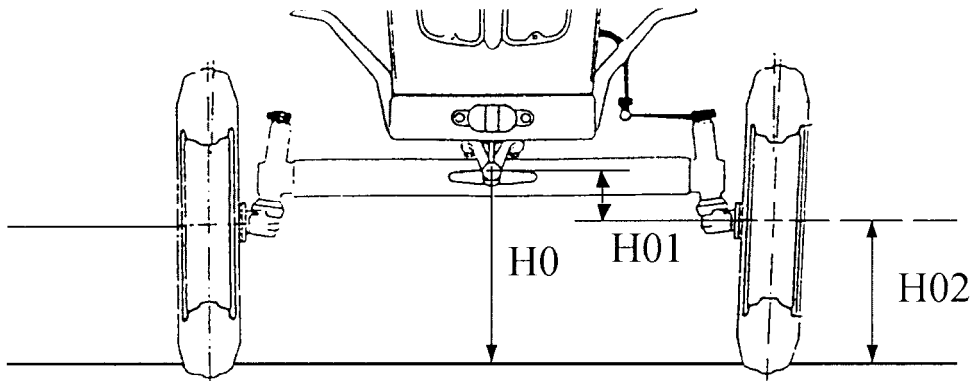

Figure 6.9

Rear track width (S) and rear tyre width (B_0)

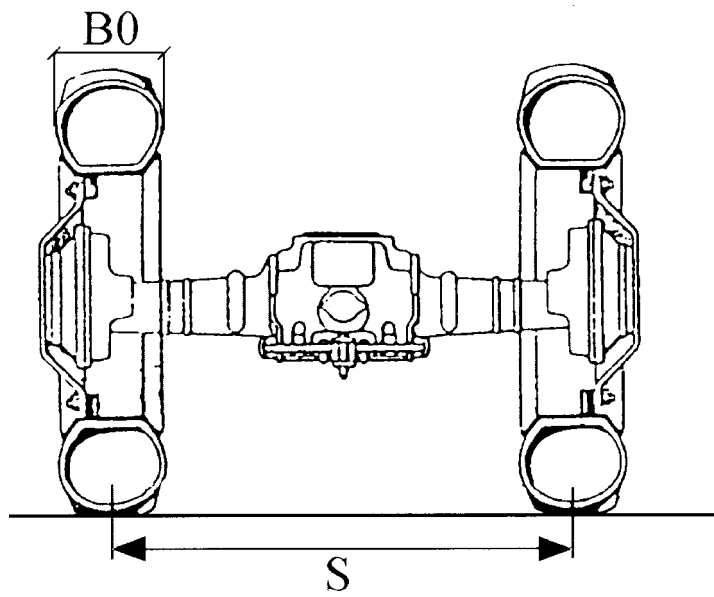

Figure 6.10

Pendulum block and its suspending chains or wire ropes

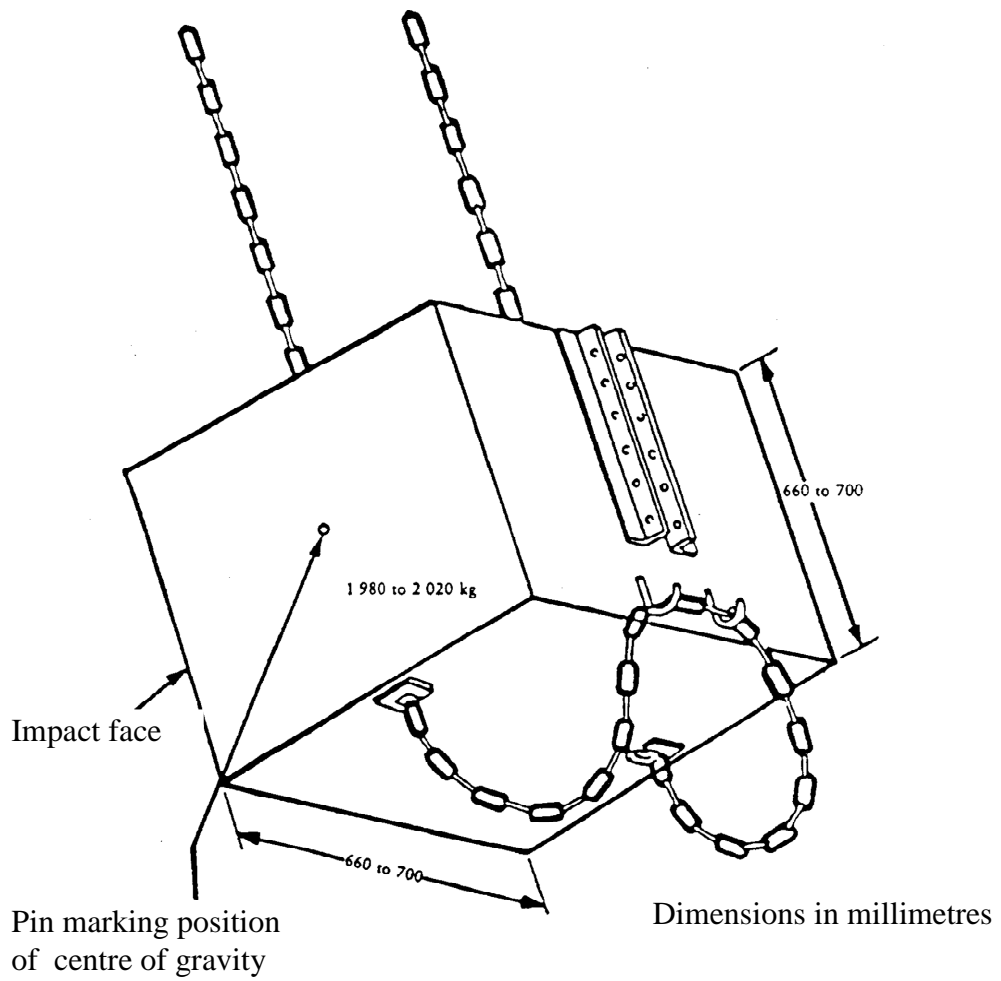

Figure 6.11

Example of tractor lashing (rear impact)

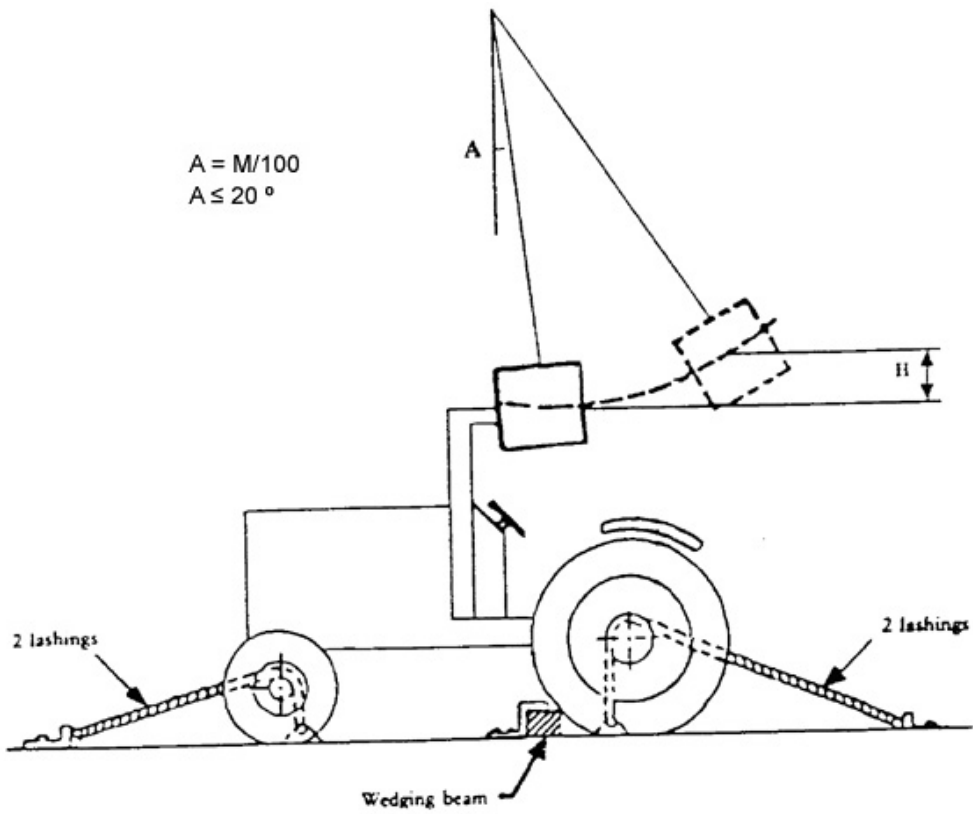

Figure 6.12

Example of tractor lashing (front impact)

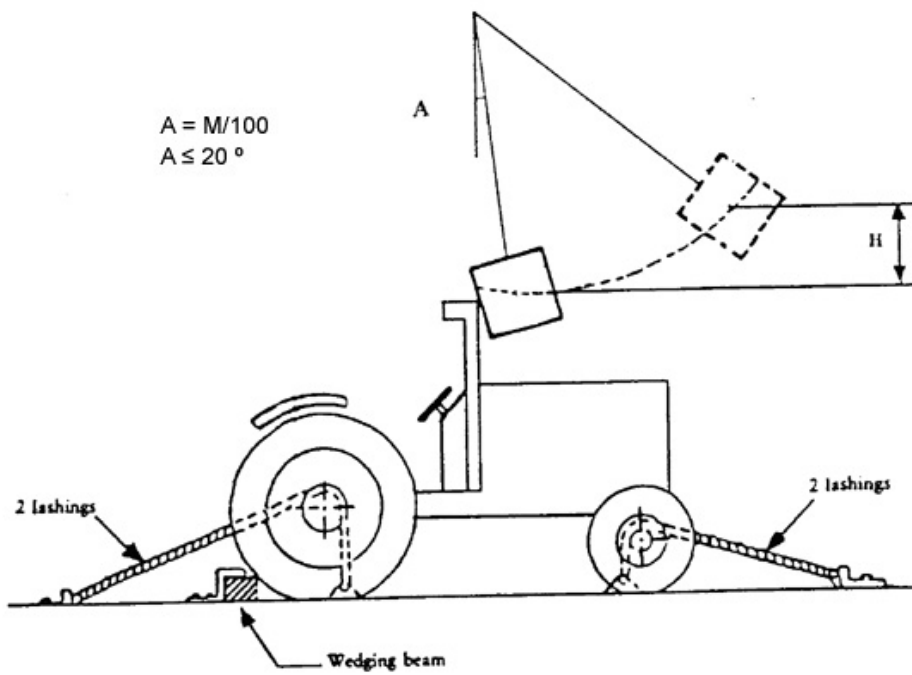
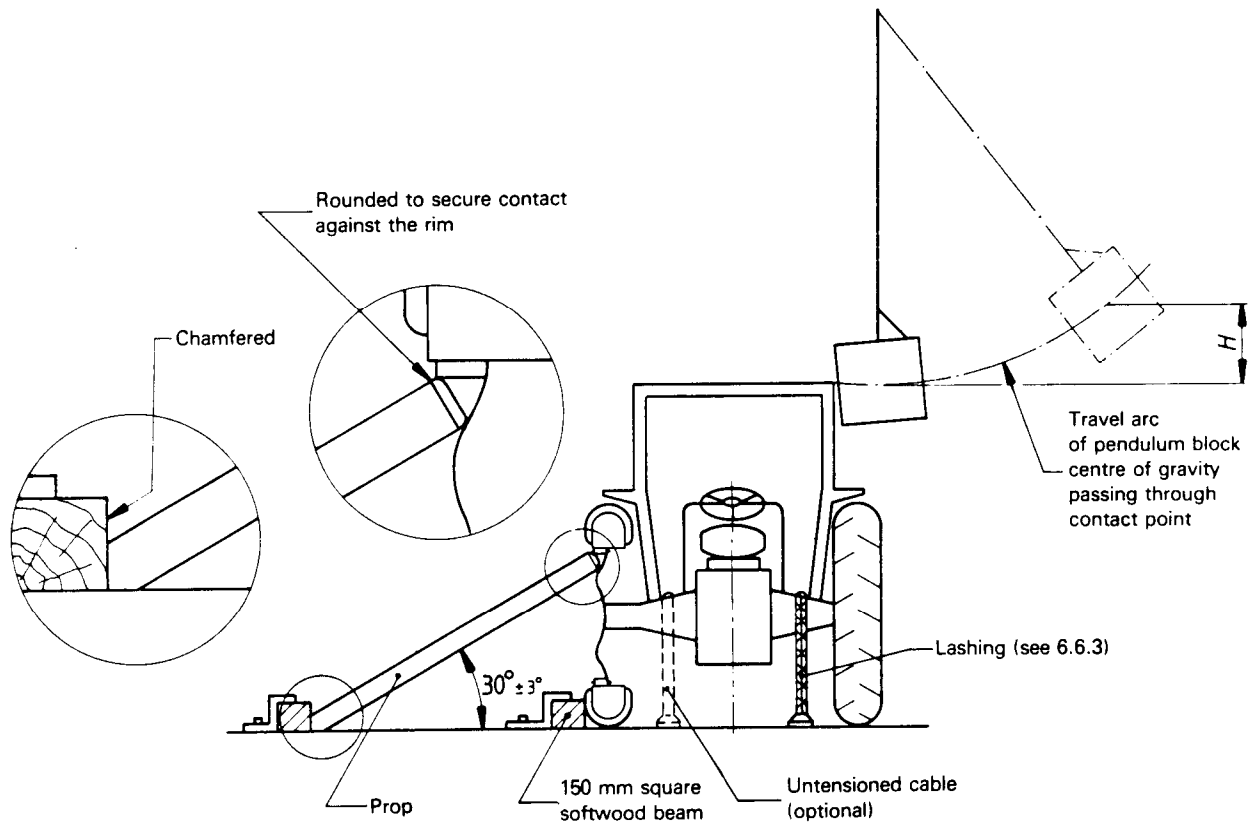

Figure 6.13

Example of tractor lashing (side impact)



Beam clamped against sides of front and rear wheels and prop wedged against wheel rim after anchoring

Figure 6.14

Example of crushing rig of the tractor

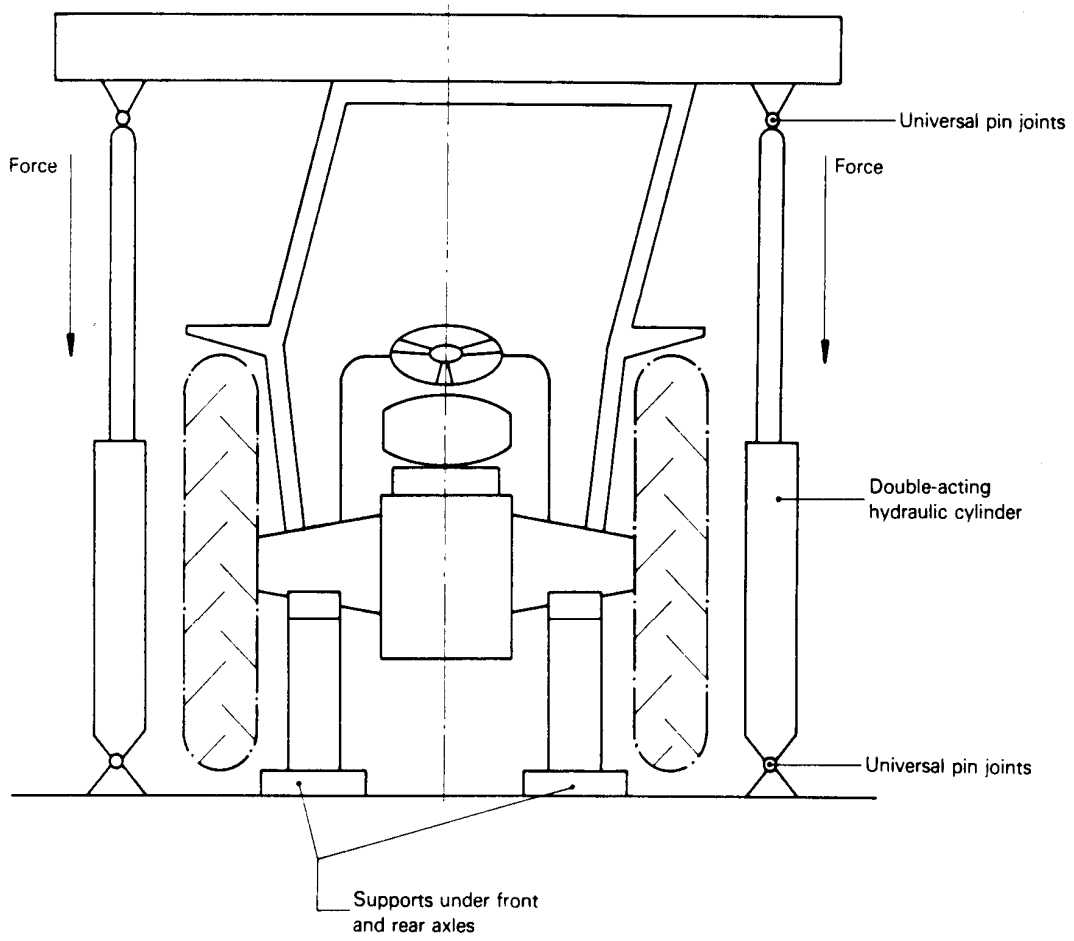
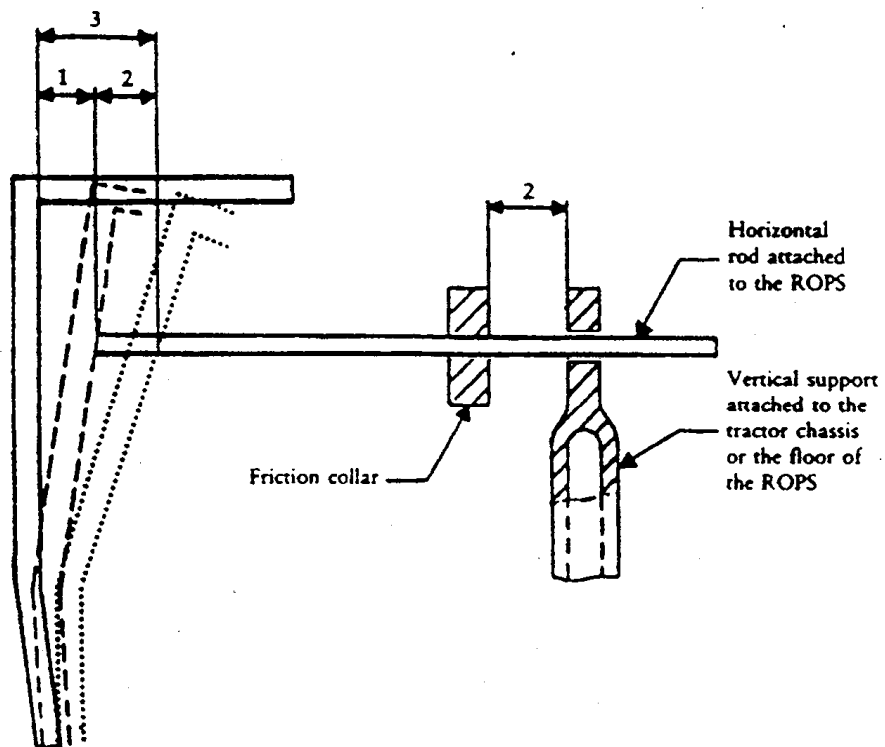

Figure 6.15

Example of apparatus for measuring elastic deflection



- 1 – Permanent deflection
- 2 – Elastic deflection
- 3 – Total deflection (permanent plus elastic)

Figure 6.16

Simulated ground line

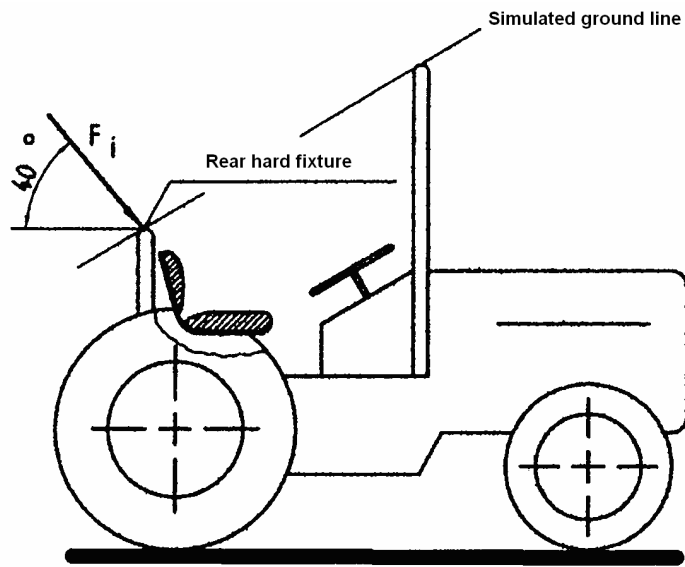

Figure 6.17

Minimum width of the rear hard fixture

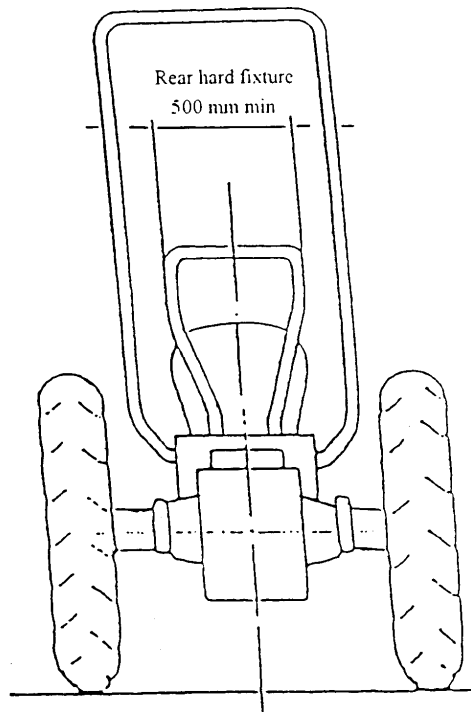
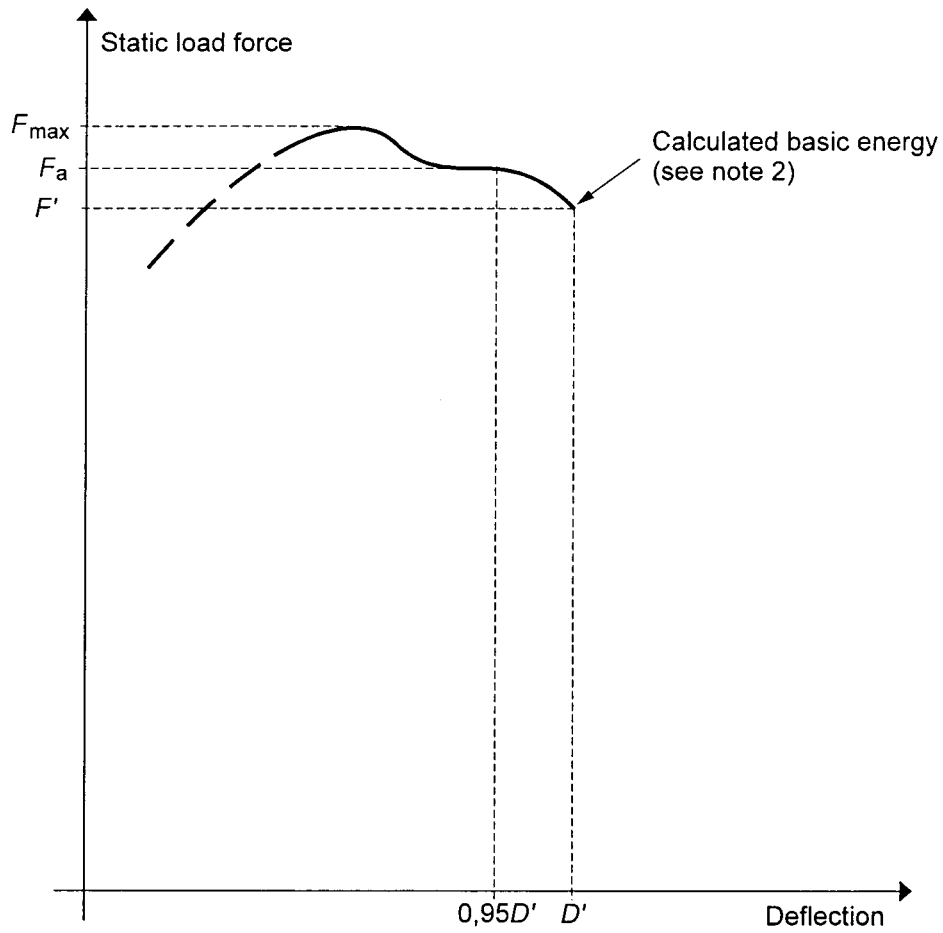

Figure 6.18

Force / deflection curve

Overload test not necessary



Notes:

1. Locate F_a in relation to $0,95 D'$.
2. Overload test not necessary as $F_a \leq 1,03 F'$.

Figure 6.19

Force / deflection curve

Overload test necessary

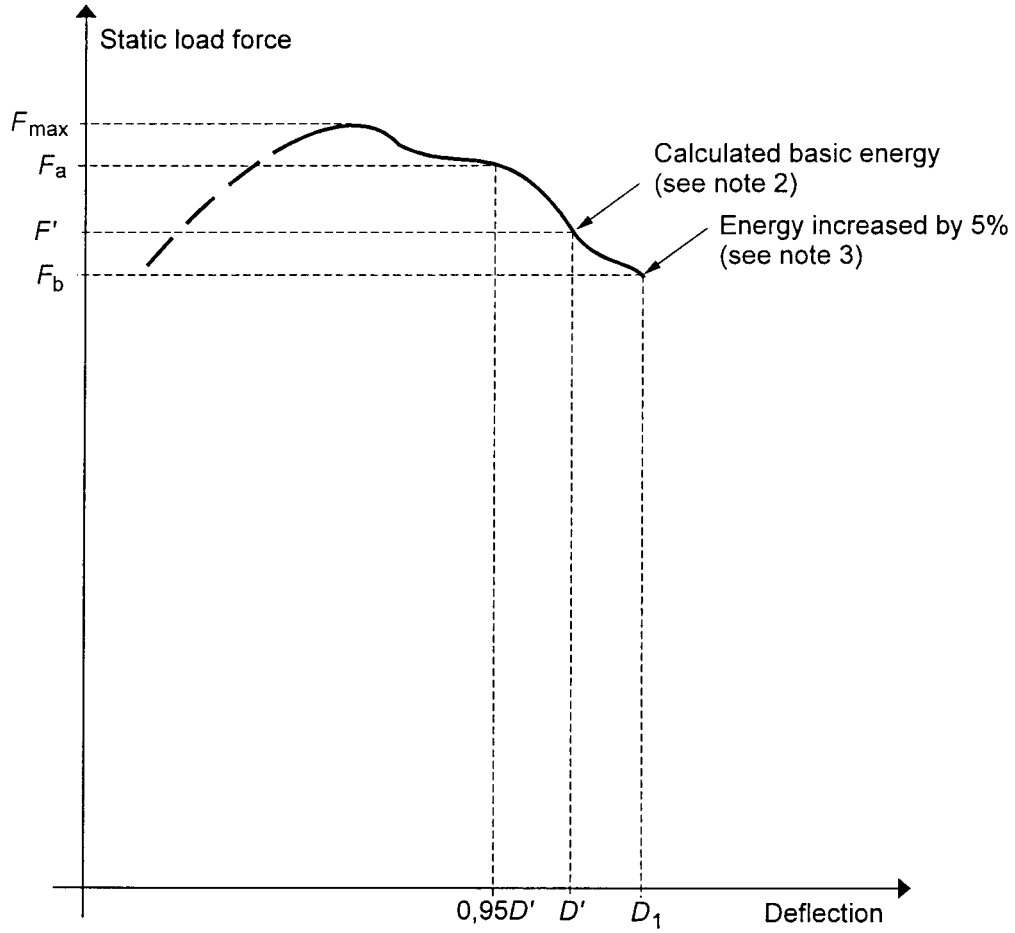

Notes:

1. Locate F_a in relation to $0,95 D'$.
2. Overload test necessary as $F_a > 1,03 F'$.
3. Overload test performance satisfactory as $F_b > 0,97F'$ and $F_b > 0,8F_{max}$.

Figure 6.20

Force / deflection curve

Overload test to be continued

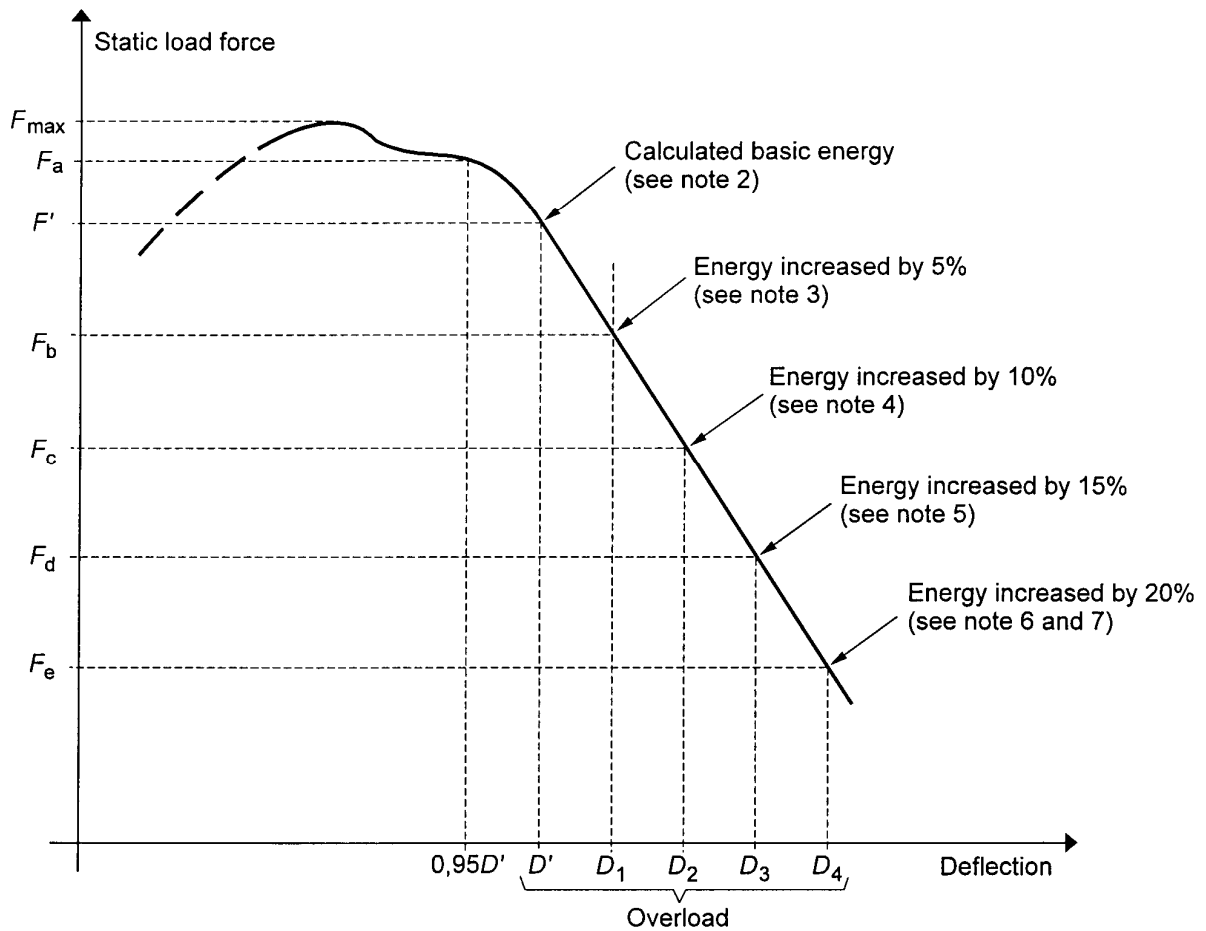

Notes:

1. Locate F_a in relation to $0,95 D'$.
2. Overload test necessary as $F_a > 1,03 F'$.
3. $F_b < 0,97 F'$ therefore further overload necessary.
4. $F_c < 0,97 F_b$ therefore further overload necessary.
5. $F_d < 0,97 F_c$ therefore further overload necessary.
6. Overload test performance satisfactory, if $F_e > 0,8 F_{max}$.
7. Failure at any stage when load drops below $0,8 F_{max}$."

ANNEX III

MODEL

REPORT RELATING TO THE EC COMPONENT TYPE-APPROVAL TEST OF A PROTECTION STRUCTURE (FRONT-MOUNTED BAR) WITH REGARD TO ITS STRENGTH AS WELL AS TO THE STRENGTH OF ITS ATTACHMENT TO THE TRACTOR

Protection structure		<div style="border: 1px solid black; padding: 5px; display: inline-block;">Identification of test station</div>
Make		
Type		
Tractor make		
Tractor type		
Test method	I/II ⁽¹⁾	

EC-component type-approval No:

1. Trade mark or name of protection structure:
2. Name and address of manufacturer of tractor or protection structure:
3. If applicable, name and address of tractor or protection structure manufacturer's authorized representative:
4. Specifications of tractor on which the tests are carried out
 - 4.1. Trade mark or name:
 - 4.2. Type:
 - 4.3. Serial number:
 - 4.4. Wheelbase/moment of inertia⁽¹⁾ mm/kgm² ⁽¹⁾
 - 4.5. Tyre sizes: front: rear:
5. Extension of EC component type-approval to other tractor types
 - 5.1. Trade mark or name:
 - 5.2. Type:
 - 5.3. Mass of unballasted tractor, with roll-over protection structure fitted, without driver: kg

⁽¹⁾ Delete where inapplicable.

- 5.4. Tyre sizes: front
rear
6. **Specifications of protection structure**
- 6.1. General arrangement drawing of both the protection structure and its attachment to the tractor
- 6.2. Photographs showing mounting details
- 6.3. Brief description of roll-over protection structure including type of construction, details of mounting on the tractor, details of cladding, means of access and escape, details of interior padding and features to prevent continuous rolling
- 6.4. Dimensions
- 6.4.1. Height of roof members above the loaded tractor seat/above the seat reference point ⁽¹⁾ . . . mm
- 6.4.2. Height of roof members above the tractor platform
- 6.4.3. Minimum distance from the steering wheel rim to the protection structure
- 6.4.4. Overall height of the tractor with the protection structure fitted
- 6.4.5. Overall width of the protection structure:
- 6.5. Details and quality of materials used, standards used:
- Main frame: (material and dimensions)
- Mountings: (material and dimensions)
- Roof: (material and dimensions)
- Interior padding: (material and dimensions)
- Assembly and mounting bolts: (grade and dimensions)
7. **Test results**
- 7.1. Impact/load ⁽¹⁾ and crushing tests
- Impact/load tests were made to the left/right-hand ⁽²⁾ rear and to the right/left-hand ⁽²⁾ front and right/left-hand side ⁽²⁾. The reference mass used for calculating impact energies and crushing forces was
- The test requirements concerning fractures or cracks, maximum instantaneous deflection and the zone of clearance were/were not ⁽²⁾ satisfactorily fulfilled.
- 7.2. Deflection measured after the tests
- Permanent deflection:
- rear: left-hand: mm
right-hand: mm
- front: left-hand: mm
right-hand: mm

⁽¹⁾ Delete where inapplicable, according to the test method used.
⁽²⁾ Delete where inapplicable.

side sideways:

front: mm

rear: mm

top downwards:

front: mm

rear: mm

Difference between maximum momentary and residual deflection during sideways impact test:

..... mm

►⁽¹⁾ 7.3. Indication and results of any additional dynamic test ◀

8. Report number:

9. Report date:

10. Signature:

→₁⁽¹⁾←

ANNEX IV

MARKS

The EC component type-approval mark consists of:

↓ 2000/22/EC Art. 1 and Annex pt. 4 (adapted)
→₁ 2003 Act of Accession Art. 20 and Annex I, pt. (1)(A)(31), p. 62
→₂ 2006/96/EC Art. 1 and Annex, Part A, pt. 30

- a rectangle surrounding the lower case letter “e” followed by the distinguishing number of the Member State which has granted the EC component type-approval:

1 for Germany, 2 for France, 3 for Italy, 4 for the Netherlands, 5 for Sweden, 6 for Belgium, →₁ 7 for Hungary, 8 for the Czech Republic, ← 9 for Spain, 11 for the United Kingdom, 12 for Austria, 13 for Luxembourg, 17 for Finland, 18 for Denmark, →₂ 19 for Romania, ← →₁ 20 for Poland, ← 21 for Portugal, 23 for Greece, 24 for Ireland, →₁ 26 for Slovenia, 27 for Slovakia, 29 for Estonia, 32 for Latvia, →₂ 34 for Bulgaria, ← 36 for Lithuania, ⊠ 49 ⊠ for Cyprus, ⊠ 50 ⊠ for Malta, ←

↓ 87/402/EEC (adapted)

- the EC component type-approval number which corresponds to the number of the EC component type-approval certificate issued with regard to the strength of the type of protection structure and its attachment to the tractor placed under and in the vicinity of the rectangle,
- the letters V or SV, depending on whether a dynamic (V) or static (SV) test was conducted, followed by the number 2, indicating that this is a protection structure within the meaning of the Directive.

EXAMPLE OF AN EC COMPONENT TYPE-APPROVAL MARK

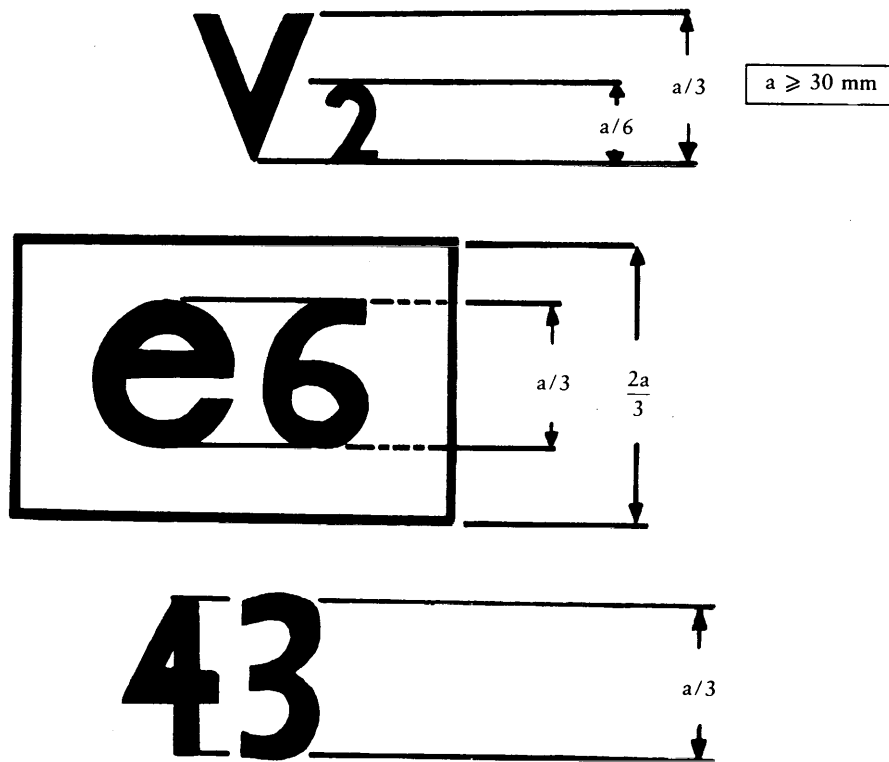

Legend: The protection structure bearing the EC component type-approval mark shown above is a structure of the bar type subjected to a dynamic test with two front-mounted uprights intended for a narrow-track tractor (V2), for which EC component type-approval was granted in Belgium (e6) under the number 43.

ANNEX V

MODEL EC COMPONENT TYPE-APPROVAL CERTIFICATE

Name of competent authority

notification concerning the granting, refusal, withdrawal or extension of EC component type-approval with regard to the strength of a protection structure (front-mounted bar) and to the strength of its attachment to the tractor

EC component type-approval No:
.....extension⁽¹⁾

1. Trade name or mark and type of protection structure:
.....
2. Name and address of manufacturer of protection structure:
.....
3. If applicable, name and address of authorised representative of manufacturer of protection structure:
.....
.....
4. Trade mark or name and type of tractor for which protection structure is intended:
.....
.....
5. Extension of EC component type-approval for the following tractors type(s):
.....
- 5.1. The mass of the unballasted tractor, as defined in point 2.1 of Model A of Annex I to Directive 2003/37/EC , exceeds/does not exceed⁽²⁾ the reference mass used for the test by more than 5 %.
- 5.2. The method of attachment and points of attachment are/are not ⁽²⁾ identical.
- 5.3. All the components likely to serve as supports for the protection structure are/are not ⁽²⁾ identical.
6. Date of submission for EC component type-approval:
7. Test station:
8. Date and number of the report of the test station:
9. Date of granting/refusal/withdrawal of EC component type-approval⁽²⁾:
10. Date of granting/refusal/withdrawal of the extension of EC component type-approval⁽²⁾:
11. Place:
12. Date:
13. The following documents, bearing the component EC type-approval number shown above, are annexed to this certificate (e.g. report of the test station):

14. Remarks, if any:

15. Signature:

(1) If applicable, state whether this is the first, second, etc. extension of the original EC component type-approval.

(2) Delete where inapplicable.

ANNEX VI

CONDITIONS FOR EC TYPE-APPROVAL

1. The application for EC type-approval of a tractor with regard to the strength of a protection structure and the strength of its attachment to the tractor is submitted by the tractor manufacturer or by his authorised representative.
 2. A tractor representative of the tractor type to be approved, on which a protection structure and its attachment, duly approved, are mounted, must be submitted to the technical services responsible for conducting the EC type-approval tests.
 3. The technical service responsible for conducting the EC type-approval test checks whether the approved type of protection structure is intended to be mounted on the type of tractor for which the EC type-approval is requested. In particular, it must ascertain that the attachment of the protection structure corresponds to that which was used when the EC component type-approval was granted.
 4. The holder of the EC type-approval may ask for its extension for other types of protection structures.
 5. The competent authorities grant such extension on the following conditions:
 - 5.1. The new type of protection structure and its tractor attachment must have received EC component type-approval.
 - 5.2. It is designed to be mounted on the type of tractor for which the extension of the EC type-approval is requested.
 - 5.3. The attachment of the protection structure to the tractor must correspond to that which was tested when EC component type-approval was granted.
 6. A certificate, of which a model is shown in Annex VII, is annexed to the EC type-approval certificate for each type-approval or type-approval extension which has been granted or refused.
 7. If the application for EC type-approval for a type of tractor is introduced at the same time as the request for EC component type-approval for a type of roll-over protection structure intended to be mounted on the type of tractor for which EC type-approval is requested, the checks laid down in points 2 and 3 are not applicable.
-

ANNEX VII

MODEL

Name of competent authority

ANNEX TO THE EC TYPE-APPROVAL CERTIFICATE FOR A TRACTOR TYPE WITH REGARD TO THE STRENGTH OF PROTECTION STRUCTURES (FRONT-MOUNTED BAR) AND THE STRENGTH OF THEIR ATTACHMENT TO THE TRACTOR

(Article 4(1) of Directive 2003/37/EC of the European Parliament and of the Council of 26 May 2003 on type-approval of agricultural or forestry tractors, their trailers and interchangeable towed machinery, together with their systems, components and separate technical units and repealing Directive 74/150/EEC)

EC component type-approval No:
.....extension⁽¹⁾

1. Trade name or mark of tractor:
2. Tractor type:
3. Name and address of tractor manufacturer:
4. If applicable, name and address of manufacturer's authorised representative:
5. Trade name or mark of protection structure:
6. Extension of EC type-approval for the following type(s) of protection structure:
7. Date tractor submitted for EC type-approval:
8. Technical service responsible for EC type-approval conformity control:
9. Date of report issued by that service:.....
10. Number of report issued by that service:.....
11. EC type-approval with regard to the strength of the protection structures and the strength of their attachment to the tractor has been granted/refused⁽²⁾:
12. The extension of EC type-approval with regard to the strength of the protection structures and the strength of their attachment to the tractor has been granted/refused⁽²⁾:
13. Place:
14. Date:
15. Signature:

⁽¹⁾ If applicable, state whether this is the first, second, etc. extension of the original EC type-approval.
⁽²⁾ Delete where inapplicable.



ANNEX VIII

Part A

Repealed Directive with list of its successive amendments (referred to in Article 13)

Council Directive 87/402/EEC
(OJ L 220, 8.8.1987, p. 1)

Council Directive 89/681/EEC
(OJ L 398, 30.12.1989, p. 27)

Point XI.C.II.6 of Annex I to the 1994 Act of
Accession
(OJ C 241, 29.8.1994, p. 205)

Commission Directive 2000/22/EC
(OJ L 107, 4.5.2000, p. 26)

Point I.A.31 of Annex II to the 2003 Act of Accession
(OJ L 236, 23.9.2003, p. 53)

Commission Directive 2005/67/EC
(OJ L 273, 19.10.2005, p. 17)

Only Article 3 and Annex III

Council Directive 2006/96/CE
(OJ L 363, 20.12.2006, p. 81)

Only as regards the reference to
Directive 87/402/EEC in Article 1
and point 30 of Part A of the Annex

Commission Directive 2010/22/EU
(OJ L 91, 10.4.2010, p. 1)

Only Article 4 and Annex IV

Part B

List of time-limits for transposition into national law and application (referred to in Article 13)

Directive	Time-limit for transposition	Date of application
87/402/EEC	26 June 1989	
89/681/EEC	3 January 1991	
2000/22/EC	30 June 2001 ^(*)	
2005/67/EC	31 December 2005	
2006/96/EC	1 January 2007	
2010/22/EU	30 April 2011	1 May 2011

(*) In accordance with Article 2 of Directive 2000/22/EC:

"1. From 1 July 2001, Member States may not:

- refuse, for a type of tractor, to grant EC type-approval or issue the document provided for in the third indent of Article 10(1) of Directive 74/150/EEC, or to grant national type-approval, or
- prohibit the first entry into service of tractors,

if those tractors comply with the requirements of Directive 87/402/EEC, as amended by this Directive.

2. From 1 January 2002, Member States:

- may no longer issue the document provided for in the third indent of Article 10(1) of Directive 74/150/EEC for a type of tractor if it does not comply with the requirements of Directive 87/402/EEC, as amended by this Directive,
- may refuse to grant national type-approval for a type of tractor if it does not comply with the requirements of Directive 87/402/EEC, as amended by this Directive."

ANNEX IX

CORRELATION TABLE

Directive 87/402/EEC	Directive 2000/22/EC	This Directive
Article 1, introductory sentence		Article 1, introductory sentence
Article 1, first indent		Article 1, point (a)
Article 1, second indent		Article 1, point (b)
Article 1, third indent		Article 1, point (c)
Articles 2 and 3		Articles 2 and 3
Article 4(1)		Article 4, first paragraph
Article 4(2)		Article 4, second and third paragraphs
Article 5		Article 5
Article 6(1), first sentence		Article 6(1), first subparagraph
Article 6(1), second sentence		Article 6(1), second subparagraph
Article 6(1), third sentence		Article 6(1), third subparagraph
Article 6(2)		Article 6(2)
Article 7, first sentence		Article 7, first paragraph
Article 7, second sentence		Article 7, second paragraph
Article 8		–
–	Article 2(1), introductory wording	Article 8(1), introductory wording
–	Article 2(1), first indent	Article 8(1)(a)
–	Article 2(1), second indent	Article 8(1)(b)
–	Article 2(2)	Article 8(2)
Articles 9 to 11		Articles 9 to 11
Article 12		–

Article 13(1)

Article 13(2)

–

Article 14

Annexes I and II

Annex VI

Annex VII

Annex VIII

Annex IX

Annex X

–

–

–

Article 12

Articles 13 and 14

Article 15

Annexes I and II

Annex III

Annex IV

Annex V

Annex VI

Annex VII

Annex VIII

Annex IX